



METALWORKING

FULL-LINE CATALOG

SAWING | TURNING | MILLING | DRILLING | GRINDING & FINISHING | FORMING

STAND BEHIND YOUR WORK



350+ SERVICE CENTERS NATIONWIDE

INDUSTRY LEADING WARRANTIES

EXPERT TECHNICAL SERVICE

JET TAKES PRIDE IN PROVIDING YOU WITH THE BEST IN METALWORKING MACHINERY. WE KNOW YOU TAKE PRIDE IN WHAT LEAVES YOUR SHOP. RUGGED-BUILT TO WITHSTAND THE VIBRATION AND POUNDING OF CONSTANT USE, JET METALWORKING MACHINES DELIVER PRECISION RESULTS TIME AFTER TIME.

Nothing compares to the feeling of pride you get looking across your shop floor with nothing but JET as far as the eye can see. Every operation of your production line can be trusted to JET Metalworking. Reliable, quality engineering and manufacturing goes into each and every JET machine. Machinists find JET easy to use, easy to maneuver and safe to operate with a full line of accessories which give you the flexibility to create without limits.

Your JET shop is backed by the industry's most comprehensive warranties and post sale service support programs. While our machines are built to last, you can rely on JET to be there in the event that something goes wrong. Visit any of our over 350 authorized JET dealers nationwide to see for yourself why so many rely on JET.

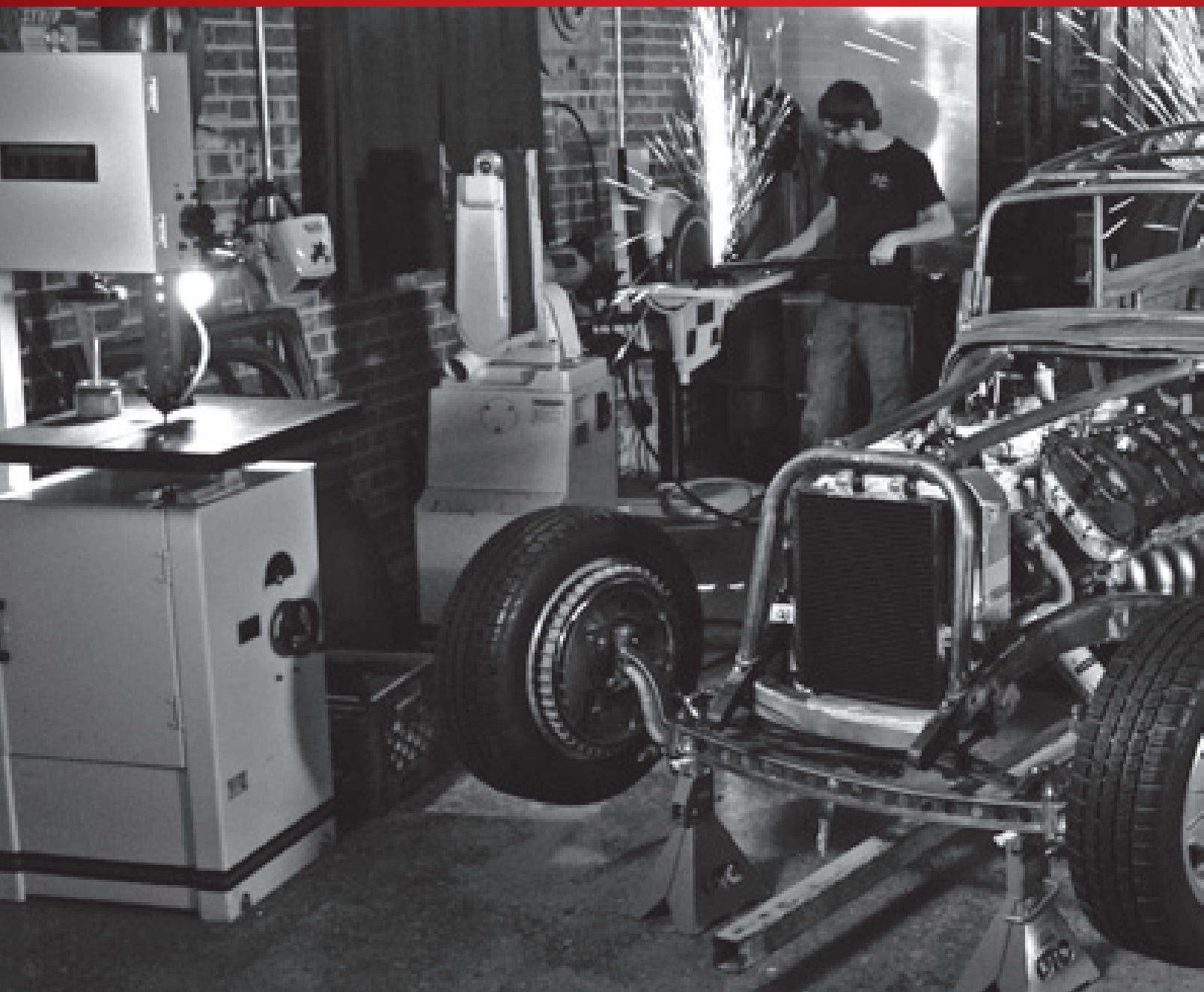



CONTENTS

SAWING 4-33

HORIZONTAL BANDSAWS	6-23
HORIZONTAL/VERTICAL BANDSAWS	24-25
VERTICAL BANDSAWS	26-27
COLDSAWS	28-30
ACCESSORIES	31
SAWING HELPFUL INFO	32-33

TURNING 34-61

CNC LATHE	36-37
LARGE SPINDLE BORE LATHES	38-43
GEARED HEAD ENGINE LATHES	44-51
BELT DRIVE LATHES	52-53
ACCESSORIES	54-57
DIGITAL READOUTS	58-59
TURNING HELPFUL INFO	60-61

MILLING 62-89

CNC VERTICAL MILL	64-66
VARIABLE SPEED VERTICAL MILLS	68-75
STEP PULLEY MILLS	76-79
MILL/DRILL	80-81
ACCESSORIES	82-85
DIGITAL READOUTS	86-87
MILLING HELPFUL INFO	88-89

DRILLING 90-111

ARM RADIAL DRILL PRESS	92-95
DIRECT DRIVE DRILL PRESS	96
GEARED HEAD DRILL PRESS	97-101
ELECTRONIC VARIABLE SPEED DRILL PRESSES ..	102-105
BENCH AND FLOOR DRILL PRESSES	106-108
ACCESSORIES	109
DRILLING HELPFUL INFO	110-111

GRINDING & FINISHING .. 112-127

BELT AND DISC MACHINES	114-117
BELT GRINDERS	118-121
DISC GRINDERS	122-123
BENCH GRINDERS	124
METAL DUST COLLECTOR	125
FINISHING HELPFUL INFO	126-127

FORMING 128-147

SHEARS	130-133
BRAKES	134-137
SLIP ROLLS	138-139
ROTARY MACHINE/ NOTCHER	140
PLANISHING HAMMER	141
ENGLISH WHEEL	142
PRESSES	143-144
PIPE BENDER	145
FORMING HELPFUL INFO	146-147

RED ASSURANCE AND WARRANTY 148-149



SAWING

Craftsmen who demand excellence rely on JET saws. Whether on location or in the shop - projects big or small - the finished product is always finer with JET manufactured saws and accessories. Whatever the job requires there is a high-production JET saw that can deliver precision results. Professional user manuals help you put JET saws to work faster, safer and more efficiently. Because JET backs all its machines with the industry's top warranty, you can have confidence that your JET machines will continue providing superior cuts every time you flip the switch.



PRECISION BUILT AND DESIGNED TO LAST



CONTENTS

HORIZONTAL BANDSAWS	6-23
HORIZONTAL/VERTICAL BANDSAWS.....	24-25
VERTICAL BANDSAWS	26-27
COLDSAWS.....	28-30
ACCESSORIES	31
SAWING HELPFUL INFO	32-33

10" HORIZONTAL AUTO SAW

Digital electronic controls and linear encoder on the JET AB-1012W Fully Automatic Pivoting Bandsaw ensure consistent accuracy and speed for variable cut and feed settings.

The Control Panel offers operation in 10 different languages, and displays clear malfunction and solution messages, enabling every user the capability to resolve errors without calling for assistance.

A frame cast in durable graphite ductile iron which reduces vibration during cutting for improved precision and enhanced transmission torque gives 30% more productivity when cutting steel and stainless steel.



FEATURES

- Material detecting sensor
- Bundle cutting
- Broken blade sensor
- Heavy-duty taper bearing in blade wheels
- Vise pressure regulator
- 10 PLC-controlled programs
- 3300 lbs load capacity
- Saw Frame-work height selector
- Automatic chip-cleaning system
- Dual-vise shuttle feeding system
- Heavy-duty one-piece base assembly
- Power driven blade brush
- Hydraulic blade tensioning system
- Large ball-bearing supporting the blade guides
- Material-size sensor for rapid travel
- Inverter blade speed control

STANDARD EQUIPMENT

- 2 Meter (6.5 ft) Roller Stand
- Chip Cart
- Work Lamp
- Out of Stock Sensor
- Full Stroke Vises
- Bundle Clamps
- Power Driven Blade Cleaning Brush
- Numerical Control Feed and Speed System
- PLC Memorize Programmable Cutting (10 programs)
- Auger-Type Hydraulic/Automatic Chip Conveyor
- Hydraulic Vertical Press Clamping (Nesting Fixture)
- Blade Breakage Detector
- Inverter Blade Speed Control
- Dual Vise Shuttle System
- Saw Frame Work Height Selector
- Hydraulic Blade Tension
- Vise Pressure Regulator



EASY TO USE SELECTION CHART AND DIAL FOR SPEEDS/MATERIALS

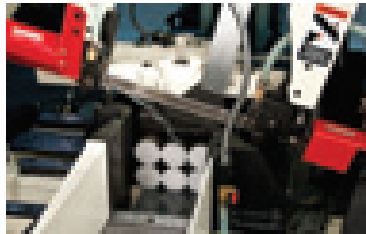

BUNDLING ATTACHMENT

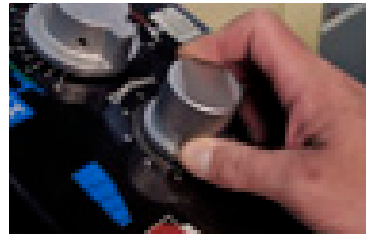

BOW DOWN-FEED RATE SETS THE CUTTING ADVANCE RATE



AUTOMATIC CHIP CLEANING SYSTEM



NESTLING CLAMPS

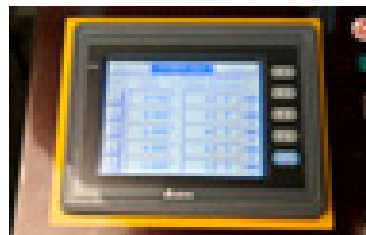

LARGE TOUCH SCREEN CONTROL



STOCK NUMBER	414462
Model Number	AB-1012W
CUTTING CAPACITIES	
Round Diameter (in.)	10
Rectangle (W x H)	10 x 12
Bundle Width (in.)	6 - 10
Bundle Height (in.)	4 - 6
Minimum Residual Work Length (in.)	2
Maximum Feeding Stroke (in.)	15-3/4
Minimum Stock Diameter (in.)	3/8
No Material Detecting Diameter (in.)	1-1/4
PLC-NC Programmable Cutting Quantities	10 programs
Work Load Capacity (lbs.)	3,306

Blade Size (in.)	1 x 0.035 x 138
Blade Speed (ft/min)	88 - 295
Blade Speed (m/min)	27 - 90
Main Motor	3HP, 230V, 3Ph
Coolant Motor	1/6HP
Hydraulic Motor	1HP
Coolant Tank Capacity (gal.)	10.5
Hydraulic Tank Capacity (gal.)	8
Roller Stand Load Capacity (lbs.)	2,200
Table Height (in.)	30
Floor Space Required (in./ L x W x H)	90 x 87 x 75
Net Weight (lbs.)	3,153

13" SEMI-AUTO HORIZONTAL BANDSAW

Loaded with operational and safety features, the JET HBS-1321W makes starting and completing any job a smooth operation. Loaded with special features, this JET saw is perfect for your shop or worksite.

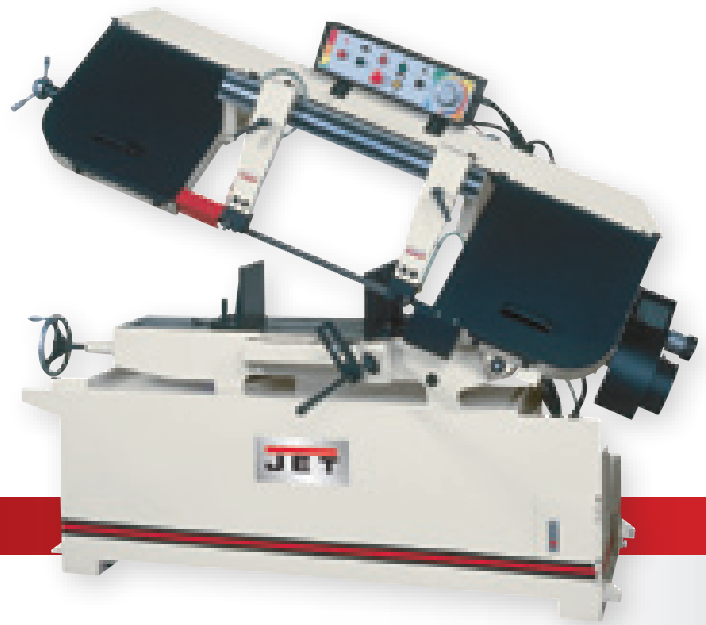

FEATURES

- Semi-automatic bow raises after cut is complete to predetermined height
- Fully adjustable hydraulic downfeed controls the rate of descent
- Quick-positioning vise lessens set-up time
- Cleaning hose and nozzle assist in washing chips away
- Easy access chip tray allows quick cleanup
- Variable blade speed allows optimum cutting performance
- Safety switch shuts off motor if band breaks
- Large hand wheel and built-in gauge provides easy blade tensioning
- Coolant is distributed through the blade guides
- Self-propelled blade brush extends the blade life

STANDARD EQUIPMENT

- Automatic shut-off after cut
- Carbide blade guides with rollers
- Coolant system
- 1-1/4VT Bi-Metal
- Adjustable material stop

STOCK NUMBER	414471
Model Number	HBS-1321W
CUTTING CAPACITIES	
Round Capacity at 90° (in.)	13
Round Capacity at 45° (in.)	10-1/2
Rectangle Capacity at 90° (in.)	10 x 21 and 13 x 19
Rectangle Capacity at 45° (in.)	11-1/2 x 10-1/2
Blade Size (in.)	1-1/4 x .042 x 161-1/2
Blade Wheel Diameter (in.)	18
Blade Speed (SFPM)	80 - 260
Bed Height (in.)	28-3/4
Motor	3HP, 230/460V, 3Ph, Prewired 230V
Floor Space Required (in./ L x W x H)	87 x 32 x 55
Net Weight (lbs.)	1,276

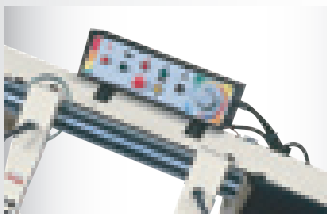

CONVENIENTLY LOCATED
CONTROL PANEL

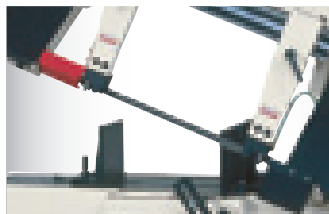

CARBIDE BLADE GUIDES WITH ROLLERS

12" x 20" SEMI-AUTOMATIC HORIZONTAL BANDSAW

This JET large capacity variable speed semi-automatic horizontal bandsaw is loaded with features that allow the operator the ability to fine tune the blade speed easily and quickly on a convenient swing away control panel. The sturdy head raises automatically after each cut and cast iron band wheels give you the confidence of quality cuts, first time, every time.



FEATURES

- Exclusive swivel control panel
- Counterbalanced feed system is controlled by a dual system of counterbalance springs working with a hydraulic cylinder
- Saw head raised hydraulically after each cut
- Variable speed drive system allows the operator to fine tune the blade speed fast and easily
- Heavy-duty transmission utilizes hardened and ground gears operating in an oil bath
- Cast iron band wheels
- Exclusively patented 3 jaw vise allows for faster set up
- Exclusive six contact point blade adjustable guide assemblies utilize cam follower bearings mounted on eccentric shafts on both sides of the blade

STANDARD EQUIPMENT

- Coolant system
- 1" Bi-metal blade
- Adjustable material stop



SWING AWAY CONTROL PANEL

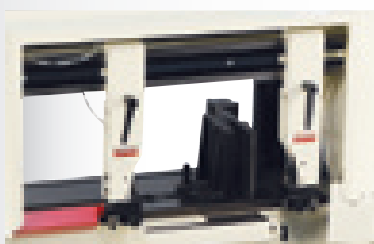

PATENTED 3-JAW VISE WHICH ALLOWS FOR FASTER SET UP

STOCK NUMBER	414476
Model Number	J-7060
CUTTING CAPACITIES	
Round Capacity at 90° (in.)	12
Round Capacity at 45° (in.)	12
Rectangle Capacity at 90° (in.)	12 x 20
Rectangle Capacity at 45° (in.)	12 x 12
Blade Size (in.)	1 x .035 x 156
Blade Wheel Diameter (in.)	17
Blade Speed (SFPM)	82 - 262
Bed Height (in.)	26-1/4
Motor	3HP, 230/460V, 3Ph, Prewired 230V
Floor Space Required (in./ L x W x H)	87 x 37-1/2 x 53
Net Weight (lbs.)	1,456
OPTIONAL EQUIPMENT	STOCK NUMBER
Replacement Blade - 1" x .035" x 156" x 4/6VT	5512107
Replacement Blade - 1" x .035" x 156" x 5/8VT	5674023
Replacement Blade - 1" x .035" x 156" x 6/10VT	5512108

10" x 18" HORIZONTAL BANDSAW

Set on a heavy-duty machined tabled bed to eliminate vibration, the JET 10" x 18" Horizontal Bandsaw delivers a precision cut time after time. Multiple operational features make this a highly desired piece of machinery for any shop.



FEATURES

- Coolant is distributed through the blade guides
- Blade guides feature parallel double-row ball bearing support
- Removable chip tray for quick clean-up
- Blade is guarded regardless of blade guide position
- Large hand wheel and built-in gauge for easy blade tensioning
- Blade brush is built-in and self-propelled
- Quick-positioning vise with fully adjustable jaws swivels to 45°
- Fully adjustable hydraulic downfeed with separate on/off valve

STANDARD EQUIPMENT

- Automatic shut-off after cut
- Carbide blade guides with rollers
- Coolant system
- 4/6VT Bi-metal blade
- Adjustable material stop

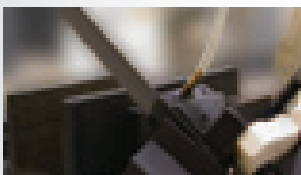

CARBIDE BLADE GUIDES



REMOVABLE CHIP TRAY



414308 BLADE

STOCK NUMBER		414473
Model Number	HBS-1018W	
CUTTING CAPACITIES		
Round Capacity at 90° (in.)	10	
Round Capacity at 45° (in.)	7-1/2	
Rectangle Capacity at 90° (in.)	10 x 16 and 6-1/2 x 18	
Rectangle Capacity at 45° (in.)	10 x 7-1/2	
Vise Swivels (deg.)	45°	
Blade Size (in.)	1 x .035 x 130-1/2	
Blade Wheel Diameter (in.)	14	
Blade Speed (SFPM)	82, 132, 210, 330	
Bed Height (in.)	23-1/2	
Motor	2HP, 230V only, 1Ph	
Floor Space Required (in./ L x W x H)	69 x 28 x 42-3/4	
Net Weight (lbs.)	705	
OPTIONAL EQUIPMENT		STOCK NUMBER
Replacement Blade - 1" x .035" x 130-1/2" x 4/6VT	414308	
Replacement Blade - 1" x .035" x 130-1/2" x 8/12VT	414310	

10" x 16" HORIZONTAL MITERING BANDSAW

Another JET saw engineered for power, accuracy and durability. The 10" x 16" Mitering Bandsaw delivers precision results for even the most exacting cuts. Variable speed drive, adjustable guide assemblies and counterbalanced feed system enhance the user experience.



414474

FEATURES

- Variable speed drive system allows the operator to fine tune the blade speed fast and easily
- Exclusive six contact point blade adjustable guide assemblies
- Combined with the side bearings are carbide pads, the back of the blade rides on two load bearings mounted on a pivot shaft so both bearings share the load equally
- Counterbalanced feed system is controlled by a dual system of counterbalance springs working with a hydraulic cylinder.
- Mitering head – the workpiece remains fixed while the head swivels to cut any angle 0° - 45°
- Heavy-duty transmission utilizes hardened and ground gears operating in an oil bath

STANDARD EQUIPMENT

- Swing away control panel
- 1" Bi-metal blade
- Cast iron blade wheels
- Coolant system
- Adjustable material stop



ADJUSTABLE MATERIAL STOP



JET EXCLUSIVE SWING AWAY CONTROL PANEL

STOCK NUMBER	414474	414475	414484
Model Number	J-7020M	J-7040M	J-7040M-4
CUTTING CAPACITIES			
Round Capacity at 90° (in.)	10	10	10
Round Capacity at 45° (in.)	8-1/2	8-1/2	8-1/2
Rectangle Capacity at 90° (in.)	2 x 16 / 10 x 14	2 x 16 / 10 x 14	2 x 16 / 10 x 14
Rectangle Capacity at 45° (in.)	8-1/2 x 9	8-1/2 x 9	8-1/2 x 9
Vise Swivels (deg.)	45	45	45
Blade Size (in.)	1 x .035 x 135	1 x .035 x 135	1 x .035 x 135
Blade Wheel Diameter (in.)	14	14	14
Blade Speed (SFPM)	100-350	100 - 350	100 - 350
Bed Height (in.)	25-1/2	25-1/2	25-1/2
Motor	1-1/2HP, 115/230V, 1Ph, Prewired 230V	2HP, 230/460V, 3Ph, Prewired 230V	2HP, 230/460V, 3Ph, Prewired 460V
Floor Space Required (in./ L x W x H)	76 x 30 x 48	76 x 30 x 48	76 x 30 x 48
Net Weight (lbs.)	1,134	1,125	1,125

10" x 16" HORIZONTAL BANDSAW

Exclusive 6-point blade guide assemblies and swivel control panel on this rugged JET saw enhance overall function and operation for superior results. Loaded with the features and backed by an industry-leading Two Year Warranty, the 10" x 16" Horizontal Bandsaw is a must for any shop operation.

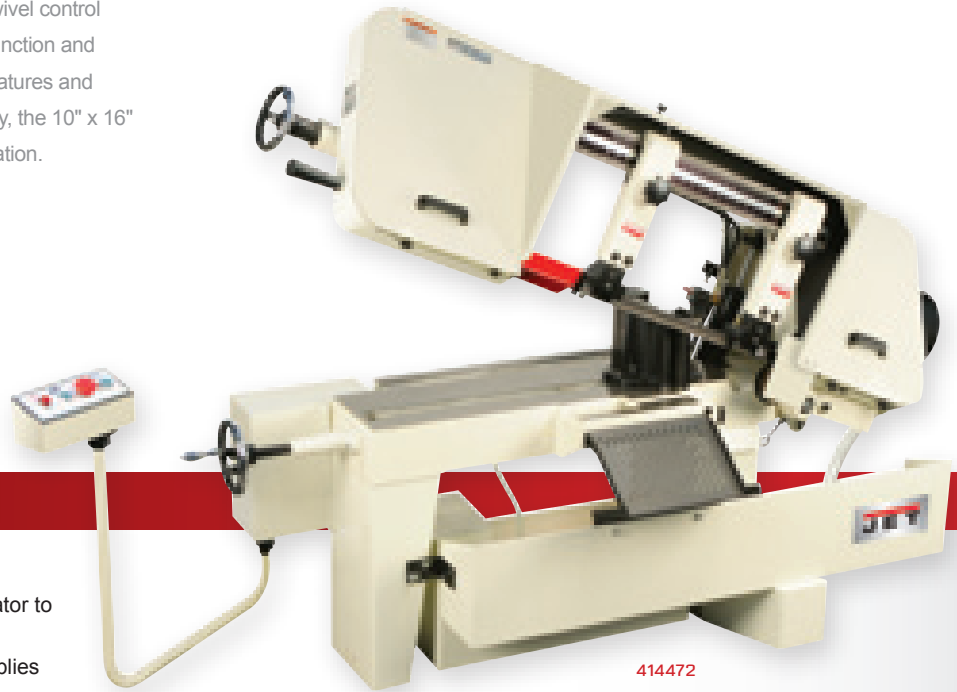

FEATURES

- Variable speed drive system allows the operator to fine tune the blade speed fast and easily
- Exclusive 6 contact point blade guide assemblies
- Exclusive swivel control panel
- 10" x 16" Horizontal Bandsaw
- One piece wheel cover
- Heavy-duty rugged transmission utilizes hardened and ground gears operating in an oil bath

STANDARD EQUIPMENT

- Swing away control panel
- Patented 3 jaw rapid action vise
- Cast iron blade wheels
- Coolant system
- 1" Bi-metal blade
- Adjustable material stop



LARGE ONE PIECE WHEEL COVER

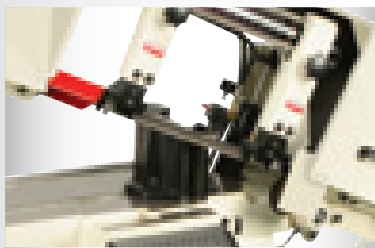

1" BI-METAL BLADE

STOCK NUMBER	414472	414478	414499
Model Number	J-7020	J-7040	J-7040-4
CUTTING CAPACITIES			
Round Capacity at 90° (in.)	10	10	10
Round Capacity at 45° (in.)	10	10	10
Rectangle Capacity at 90° (in.)	7 x 16 / 10 x 10	7 x 16 / 10 x 10	7 x 16 / 10 x 10
Rectangle Capacity at 45° (in.)	6-1/2 x 11	6-1/2 x 11	6-1/2 x 11
Blade Size (in.)	1 x .035 x 130	1 x .035 x 130	1 x .035 x 130
Blade Wheel Diameter (in.)	14	14	14
Blade Speed (SFPM)	100 - 350	100 - 350	100 - 350
Bed Height (in.)	23-1/2	23-1/2	23-1/2
Motor	1-1/2HP, 115/230V, 1Ph, Prewired 230V	2HP, 3Ph	2HP, 460V, 3Ph, Prewired 460V
Floor Space Required (in./ L x W x H)	75-1/2 x 33 x 41	75-1/2 x 33 x 41	75-1/2 x 33 x 41
Net Weight (lbs.)	927	927	927
OPTIONAL EQUIPMENT			STOCK NUMBER
Replacement Blade - 1" x .035" x 135" x 4/6VT			5674011
Replacement Blade - 1" x .035" x 135" x 5/8VT			5674022
Replacement Blade - 1" x .035" x 135" x 6/10VT			5674021

10" x 14" HORIZONTAL MITERING BANDSAW

Swiveling miter head design cuts wood and metal easily making this JET Horizontal Mitering Bandsaw the go-to machine in any shop. Easy to set up and easy to use, but rugged-built and durable to take on every project.



FEATURES

- Unique design features a swivel-head for miter cutting structurals, pipe and tubing
- Large, easy-to-read scale for positioning saw head
- Quick-positioning vise reduces set-up time
- Coolant is distributed through the blade guides
- Blade brush is built-in and self-propelled
- Miter head swivels from 90° to 45° while the stock remains in the same position
- Large handwheel and built-in gauge for easy blade tensioning
- Fully adjustable hydraulic downfeed with separate on/off valve

STANDARD EQUIPMENT

- Automatic shut-off after cut
- Carbide blade guides with rollers
- Coolant system
- 4/6VT Bi-metal blade
- Adjustable material stop

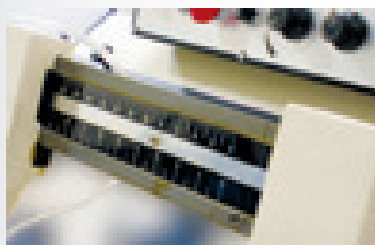

EASY-TO-READ SCALE

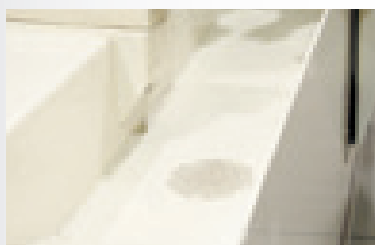

REMOVABLE CHIP TRAY

STOCK NUMBER	414479	414477
Model Number	MBS-1014W-1	MBS-1014W-3
CUTTING CAPACITIES		
Round Capacity at 90° (in.)	10	10
Round Capacity at 45° (in.)	9	9
Rectangle Capacity at 90° (in.)	10 x 14	10 x 14
Rectangle Capacity at 45° (in.)	9 x 8-1/2	9 x 8-1/2
Vise Swivels (deg.)	45	45
Blade Size (in.)	1 x .035 x 130	1 x .035 x 130
Blade Wheel Diameter (in.)	14	14
Blade Speed (SFPM)	82, 132, 210, 330	82,132,210,330
Bed Height (in.)	25	25
Motor	2HP, 230V Only, 1Ph	3 HP, 230/460V,3Ph Prewired 230V
Floor Space Required (in./ L x W x H)	26x69x44	26 x 69 x 44
Net Weight (lbs.)	948	948
OPTIONAL EQUIPMENT		STOCK NUMBER
Replacement Blade - 1" x .035" x 130" x 4/6VT		414311

9" x 16" HORIZONTAL BANDSAW

Large handwheel, built-in gauge, blade guides, quick-positioning vise and removable chip tray are but a few of the features that make this JET Horizontal Bandsaw among the best when compared to the competition. Efficiency, precision and functionality combined to deliver superior results time after time.



FEATURES

- Large hand-wheel and built-in gauge for easy blade tensioning
- Quick-positioning vise with fully adjustable jaws swivels to 45°
- Removable chip tray for quick clean-up
- Blade is fully guarded regardless of blade guide position
- Blade guides feature parallel double row ball bearing support
- Coolant is distributed through the blade guides
- Blade brush is built-in and self-propelled
- Fully adjustable hydraulic downfeed with separate on/off valve

STANDARD EQUIPMENT

- Automatic shut-off after cut
- Carbide blade guides with rollers
- Coolant system
- 4/6VT Bi-metal blade
- Adjustable material stop

STOCK NUMBER	414468
Model Number	HBS-916W
CUTTING CAPACITIES	
Round Capacity at 90° (in.)	9
Round Capacity at 45° (in.)	6-1/8
Rectangle Capacity at 90° (in.)	2 x 16 / 8-1/2 x 14
Rectangle Capacity at 45° (in.)	9 x 6-1/8
Vise Swivels (deg.)	45
Blade Size (in.)	1 x .035 x 119-1/2
Blade Wheel Diameter (in.)	13
Blade Speed (SFPM)	82, 132, 170, 235
Bed Height (in.)	25
Motor	1-1/2HP, 115/230V, 1Ph, Prewired 115V
Floor Space Required (in./ L x W x H)	65 x 28 x 42
Net Weight (lbs.)	625



EASY-TO-READ SCALE

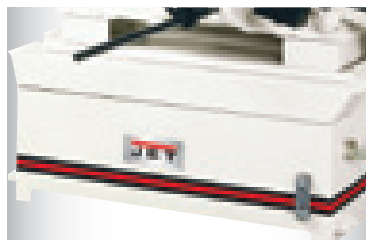

REMOVABLE CHIP TRAY



BLADE IS FULLY GUARDED

7" and 8-3/4" ZIP MITER HORIZONTAL BANDSAW

Ideal for miter cuts up to 60 degrees and suitable when metal sawing applications of 7" and 8-3/4" cuts are required, JET Zip Mitering Saws lend versatility to machine shops large or small. Switch from hydraulic descent to trigger switch and handle manual cutting, but either way this JET saw delivers super results with every cut. Backed by an industry-leading Two Year Warranty



Ergonomically designed for optimal user comfort, this impressive line of JET saws comes standard with all the features one needs to make precision cuts in a variety of materials. The miter angle takes just seconds to adjust, saving precious time during fabrication.

FEATURES

- Adjustable hydraulic feed system
- Eccentric shaft ball bearings
- Heavy-duty cast iron saw head and sturdy base
- Mitering capability to 60°
- Convenient control panel

STANDARD EQUIPMENT

- Hydraulic blade tension gauge
- Overload protection
- Quick Release vise
- Complete coolant system
- Adjustable material stop
- Bi-Metal bandsaw blade



CONTROL BOX RIGHT AT THE OPERATOR'S FINGER TIPS



HYDRAULIC BLADE TENSION GAUGE

STOCK NUMBER	414464	414467
Model Number	J-9180-3	J-9225
CUTTING CAPACITIES		
Round Capacity at 90° (in.)	7	8-3/4
Round Capacity at 45° (in.)	4-1/2	6-1/4
Rectangle Capacity at 90° (in.)	7 x 7	8-3/4 x 7
Rectangle Capacity at 45° (in.)	4-1/2 x 4-1/2	6-1/4 x 7-1/4
Vise Swivels (deg.)	60	60
Blade Size (in.)	3/4 x .035 x 82	1 x .035 x 96-1/2
Blade Speed (SFPM)	137, 275	157, 314
Blade Wheel Diameter (in.)	10-1/2	11-5/8
Bed Height (in.)	35-7/8	38-7/16
Motor	1HP, 230V, 3Ph	1-1/2HP, 230V, 3Ph
Floor Space Required (in./ L x W x H)	47 x 29 x 56-1/2	51 x 33 x 59-1/4
Net Weight (lbs.)	385	485

8 x 14" HORIZONTAL GEARED HEAD BANDSAW

The JET HBS-814GH was engineered with the operator in mind. An easy-access control panel and heavy-duty geared head transmission for quick speed change means productivity never slows. Like every JET machine we manufacture, professionals know they can rely on this saw when the project is on the line.



FEATURES

- Heavy-duty geared head transmission for quick speed changes
- Hydraulic feed
- Hardened and ground worm gears
- Easy accessible control panel for operator use
- Portable on wheels
- Miters at 45°
- Quick action vise

STANDARD EQUIPMENT

- 3/4" Bi-metal blade
- Coolant system
- Adjustable material stop
- Chip brush



EASY ACCESSIBLE CONTROL PANEL



COOLANT SYSTEM RESERVOIR



5674032 BLADE

STOCK NUMBER		414466
Model Number	HBS-814GH	
CUTTING CAPACITIES		
Round Capacity at 90° (in.)	8	
Round Capacity at 45° (in.)	6-1/2	
Rectangle Capacity at 90° (in.)	14 x 8 / 2 x 14	
Rectangle Capacity at 45° (in.)	6-1/2 (H) x 6 (W) & 2 (H) x 7 (W)	
Throat Depth (in.)	8	
Vise Swivels (deg.)	45	
Blade Size (in.)	3/4 x .035 x 97	
Blade Wheel Diameter (in.)	12	
Blade Speed (SFPM)	135, 197, 256	
Bed Height (in.)	26	
Motor	1HP, 115/230V, 1Ph, Prewired 115V	
Floor Space Required (in./ L x W x H)	51-1/2 x 18-1/8 x 44	
Net Weight (lbs.)	400	
OPTIONAL EQUIPMENT		STOCK NUMBER
Replacement Blade - 3/4" x .035" x 97" x 8R-C	5674032	
Replacement Blade - 3/4" x .035" x 97" x 5/8VT	5674033	
Replacement Blade - 3/4" x .035" x 97" x 8/12VT	5674034	

8" x 13" HORIZONTAL BANDSAW

The JET J-7015 Horizontal Bandsaw was manufactured for long-lasting, efficient use. Designed to deliver accurate cuts without undue blade fatigue, this JET saw works longer and stronger so productivity never suffers.



FEATURES

- The combination of an oil bath, gear reduction power train, along with precision blade guides and a hydraulic feed system delivers consistent, accurate cuts and longer blade life.
- Dual voltage electrics (115V/230V) with overload and low voltage protection
- Longer blade wheel base reduces blade fatigue and increases blade life
- Heavy-duty, rigid steel and cast iron construction of the head and base provides full blade support and eliminates vibration and deflection.
- Conveniently located control panel and an easily accessible coolant system
- Easy to use belt drive tensioner does not require tools for blade speed changes or belt replacement

STANDARD EQUIPMENT

- Rapid acting vise (allows miter cutting to 45°)
- Coolant system
- 1" Bi-metal blade
- Adjustable material stop



HEAVY-DUTY, RIGID STEEL & CAST IRON CONSTRUCTION OF THE HEAD PROVIDES FULL BLADE SUPPORT



RAPID ACTION VISE ALLOWS FOR MITER CUTS

STOCK NUMBER	414450
Model Number	J-7015
CUTTING CAPACITIES	
Round Capacity at 90° (in.)	9
Round Capacity at 45° (in.)	9
Rectangle Capacity at 90° (in.)	9 x 13
Rectangle Capacity at 45° (in.)	9 x 8
Blade Size (in.)	1 x .035 x 114.5
Blade Wheel Diameter (in.)	11-5/8
Blade Speed (SFPM)	82, 132, 170, 235
Bed Height (in.)	27-1/2
Motor	1.5HP, 115/230V, 1Ph, Prewired 115V
Floor Space Required (in./ L x W x H)	62-1/2 x 23 x 48
Net Weight (lbs.)	551
OPTIONAL EQUIPMENT	STOCK NUMBER
Replacement Blade - 1" x .035" x 114-1/2" x 4/6VT	5516191
Replacement Blade - 1" x .035" x 114-1/2" x 8/12VT	5516193

8" x 12" HORIZONTAL / VERTICAL GEARED HEAD BANDSAW

Innovative and built to last; that's how customers describe the latest addition to the JET line of saws. Easy speed change, quick lock vise and large 8" wheels enhance the convenience of this rugged machine. It is everything you expect from a JET saw.



FEATURES

- Gear box for ease of speed change
- UL Listed motor
- Heavy cast iron bow & head
- Hardened and ground worm gear
- Large 8" wheels and handle for easy movement in your shop
- Coolant system included

STANDARD EQUIPMENT

- Quick Lock Vise
- Vertical Worktable
- Coolant system
- Adjustable work stop
- Bi-metal blade
- Chip Brush



EASY TO USE GEAR BOX



LARGE EASY TO MOVE BASE ON 8" WHEELS

STOCK NUMBER	413460
Model Number	HBS-812G
CUTTING CAPACITIES	
Round at 90° (in.)	8
Round at 45° (in.)	5
Rectangle at 90° (in.)	8 x 11-1/4
Rectangle at 45° (in.)	5 x 8
Vise Swivels	45°
Blade Size (in.)	3/4" x .035 x 93
Blade Speeds (SFPM)	145, 208, 255
Height (in.)	43
Motor	1HP, 115/230V, 1Ph, Prewired 115V 1720 PRM
Net Weight (lbs.)	308

7" x 12" HORIZONTAL BANDSAW

The upgraded J-3410 7" x 12" bandsaw has a huge square frame and rapid acting vise for quick set up and cutting action. With a 3/4HP motor, side and rear blade guides and 3/4" bi-metal blade included this heavy-duty saw is built to last.



FEATURES

- Blade drive is steel, heat treated worm driving a bronze worm gear in oil bath
- Heavy-duty cast iron saw head and table
- Blade wheels are made of flanged cast iron
- Blade guides – side-eccentric shaft and ball bearing; rear-ball bearing
- Adjustable hydraulic feed system
- Automatic shut-off at end of cut

STANDARD EQUIPMENT

- Rapid acting vise
- 3/4" bi-metal blade with 5/8 TPI
- Coolant pump 1 gallon, 1Ph motor, complete with hose, flexible nozzle, shut-off valve, tank and baffle
- Wheel kit for convenient moving to various work stations
- Adjustable material stop

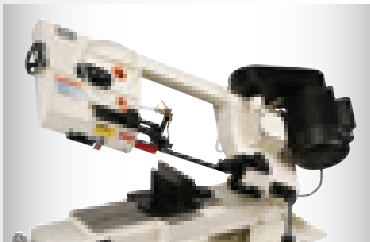

HEAVY-DUTY CAST IRON FRAME



AUTOMATIC SHUT OFF AFTER EACH CUT

STOCK NUMBER	414454	414455
Model Number	J-3410	J-3410-2
CUTTING CAPACITIES		
Round Capacity at 90° (in.)	7	7
Round Capacity at 45° (in.)	4-1/2	4-1/2
Rectangle Capacity at 90° (in.)	2 x 12 / 7 x 10-1/2	2 x 12 / 7 x 10-1/2
Rectangle Capacity at 45° (in.)	7 x 3-1/2	7 x 3-1/2
Blade Size (in.)	3/4 x .035 x 93	3/4 x .035 x 93
Blade Wheel Diameter (in.)	11-7/16	11-7/16
Blade Speed (SFPM)	80, 130, 180, 265	80, 130, 180, 265
Bed Height (in.)	23-1/2	23-1/2
Motor	3/4HP, 115V, 1Ph,	3/4HP, 220V, 1Ph
Floor Space Required (in./ L x W x H)	50 x 18 x 41	50 x 18 x 41
Net Weight (lbs.)	308	308

7" x 12" HORIZONTAL / VERTICAL BANDSAW

The JET HVBS-7MW Metalworking Bandsaw has everything any operator needs to tackle even the toughest job. It is versatile, powerful and offers safety features so you can cut with confidence. Another JET saw that exceeds expectations.



FEATURES

- UL listed motor
- Hardened and ground worm gear
- Automatic shut-off after cut
- Heavy cast iron bow and bed
- Hydraulic downfeed for ease of cut
- Roller cabinet with built-in chip tray

STANDARD EQUIPMENT

- Vertical worktable
- 3/4" Bi-metal blade with 5/8 TPI
- Coolant system
- Adjustable material stop
- Large 8" wheels for ease of movement
- Chip brush



NEW! 4 LARGE 8" WHEELS TO EASE MOVEMENT AROUND THE SHOP



HEAVY CAST IRON BOW AND BED

STOCK NUMBER	414459
Model Number	HVBS-7MW
CUTTING CAPACITIES	
Round Capacity at 90° (in.)	7
Round Capacity at 45° (in.)	4-1/2
Rectangle Capacity at 90° (in.)	2 (H) x 12 (W) / 7 (H) x 10-7/8 (W)
Rectangle Capacity at 45° (in.)	7 (H) x 3-1/2 (W) / 5-1/2 (H) x 4-1/2 (W)
Throat Depth (in.)	7
Vertical Tables (in.)	9-3/8 x 10
Vise Swivels (deg.)	45
Blade Size (in.)	3/4 x .035 x 93
Blade Wheel Diameter (in.)	11-3/4
Blade Speed (SFPM)	86, 132, 178, 260
Bed Height (in.)	23
Motor	3/4HP, 115/230V, 1Ph, Prewired 115V
Floor Space Required (in./ L x W x H)	49-1/2 x 20-1/2 x 41
Net Weight (lbs.)	286
OPTIONAL EQUIPMENT	STOCK NUMBER
Replacement Blade - 3/4" x .035" x 93" x 6/10VT	414304
Replacement Blade - 3/4" x .035" x 93" x 6R	5632142
Replacement Blade - 3/4" x .035" x 93" x 8R	5632141
Replacement Blade - 3/4" x .035" x 93" x 10R	5632151
Replacement Blade - 3/4" x .035" x 93" x 14R	5632161

7" x 10-1/2" MITERING HORIZONTAL / VERTICAL BANDSAWS

With the JET HVBS-710, everything you need to make precision cuts hour after hour is located right at the operator's fingertips. For increased versatility, a rotating disc hub allows miter cuts in both the horizontal and vertical positions. Backed by JET's industry leading Two Year Warranty.



FEATURES

- Swivel head for both horizontal and vertical miter cutting
- UL listed motor
- Heavy cast iron bow and head
- Hydraulic downfeed for ease of cut
- Hardened and ground worm gear
- Large 8" wheels and handle for easy movement in your shop

STANDARD EQUIPMENT

- Quick lock vise
- 3/4" Bi-metal blade 5/8 TPI
- Coolant system
- Adjustable material stop
- Chip brush



LARGE 8" WHEELS TO EASE MOVEMENT AROUND THE SHOP



HYDRAULIC CYLINDER WITH VALVE REGULATOR MAKING BLADE SPEED CHANGES EASY



BALL BEARING BLADE GUIDES

STOCK NUMBER	413451	413452
Model Number	HVBS-710S	HVBS-710G
Motor Drive	Belt	Geared
CUTTING CAPACITIES		
Round at 90° (in.)	7	7
Round at 45° (in.)	4	4
Rectangle at 90° (in.)	7 x 10-1/2	7 x 10-1/2
Rectangle at 60° (in.)	4-3/4 x 4	4-3/4 x 4
Blade Size (in.)	3/4" x .035 x 93 5/8 TPI	3/4" x .035 x 93 5/8 TPI
Blade Speeds (SFPM)	86, 131, 182, 260	145, 208, 255
Blade Wheel Diameter (in.)	11-3/4	11-3/4
Motor	1HP, 115/230V, 1Ph Prewired 115V	1 HP, 115/230V, 1Ph Prewired 115V
Net Weight (lbs.)	396	396

5" x 8" HORIZONTAL BANDSAW

Adjustable guides and hydraulic feed, steel worm gear and bronze drive gear, and auto shutoff at end of the cut are some of the features that makes this JET Hydraulic Band Saw a must for any professional machine shop. The built-in handle and wheels makes relocation within your workspace quick and easy.



FEATURES

- Adjustable ball bearing guides
- Heat treated steel worm gear and bronze drive gear
- Automatic shut off at end of cut
- Adjustable hydraulic feed system
- Handle and wheels for convenient moving to various work stations

STANDARD EQUIPMENT

- Eccentric shaft and ball bearing side blade guides
- Ball bearing rear blade guides
- 1 gallon capacity coolant system, 115V/1Ph, complete with hose, flexible nozzle, shut off valve, tank and baffle
- 1/2" carbon steel blade



BLADE RELIEF SLOT



CUTTING FLUID TROUGH

STOCK NUMBER		414453
Model Number	J-3230	
CUTTING CAPACITIES		
Round Capacity at 90° (in.)	5	
Round Capacity at 45° (in.)	4-1/2	
Rectangle Capacity at 90° (in.)	7-1/2 x 5	
Rectangle Capacity at 45° (in.)	4-1/2 x 5	
Blade Size (in.)	1/2 x .025 x 68	
Blade Wheel Diameter (in.)	7-1/2	
Blade Speed (SFPM)	85, 125, 200	
Bed Height (in.)	23-1/2	
Motor	1/2HP, 115V, 1Ph, 1725RPM	
Floor Space Required (in./ L x W x H)	37 x 16 x 37	
Net Weight (lbs.)	134	

5" x 6" SWIVEL HEAD BANDSAW

This Swivel Head Bandsaw from JET is loaded with features that makes it an essential piece to any shop set up. Hydraulic down feed control ensures smooth cuts; head swivels for cuts at both 45 and 60 degrees. This rugged saw boasts all the power, versatility and precision that you expect from everything JET has to offer.



FEATURES

- Hydraulic down feed control
- Deluxe enclosed stand with handle and wheels for easy movement
- Sealed worm gear transmission
- UL Listed motor
- Head swivels for a maximum cut at 45° & 60°
- Ball bearing drive wheel and blade guides

STANDARD EQUIPMENT

- 1/2" Carbon steel blade
- Adjustable material stop



HYDRAULIC DOWN FEED CONTROL



414301 BLADE



STOCK NUMBER	414457
Model Number	HBS-56S
CUTTING CAPACITIES	
Round Capacity at 90° (in.)	5
Round Capacity at 45° (in.)	3
Round Capacity at 60° (in.)	1-3/4
Rectangle Capacity at 90° (in.)	5 x 6; 2 x 6-3/4
Rectangle Capacity at 45° (in.)	4 x 2-3/4; 2 x 3-3/4
Rectangle Capacity at 60° (in.)	5 x 1-3/4
Blade Size (in.)	1/2 x .025 x 64-1/2
Blade Wheel Diameter (in.)	7-3/8
Blade Speed (SFPM)	80, 120, 200
Bed Height (in.)	28
Motor	1/2HP, 115/230V, 1Ph, Prewired 115V
Floor Space Required (in./ L x W x H)	37 x 20-3/4 x 41
Net Weight (lbs.)	172
OPTIONAL EQUIPMENT	STOCK NUMBER
Replacement Blade - 1/2" x .025" x 64-1/2" x 14R-C	414301

5" x 6" HORIZONTAL / VERTICAL BANDSAW

Smaller shops and job sites alike benefit from the power and precision of JET when the HVBS-56M is put into action. Its 1/2HP, UL motor offers great versatility and power when cutting in either a horizontal or vertical position.

Long list of features and JET backed Two Year Warranty make this saw a must have for your operation.



FEATURES

- Exclusive design heavy-duty 14-gauge stand
- Heat-treated and ground steel worm gear with bronze drive gear
- Automatic shut-off after cut
- UL Listed single phase motor
- Large diameter wheels and built-in handle allows easy movement
- Front legs feature adjustable leveling pads
- Ball bearing supported blade wheel
- Fully adjustable ball bearing blade guides
- Three blade speeds

STANDARD EQUIPMENT

- Vertical worktable
- Adjustable material stop
- 1/2" Carbon steel blade



SAW IN VERTICAL POSITION

STOCK NUMBER	414458
Model Number	HVBS-56M
CUTTING CAPACITIES	
Round Capacity at 90° (in.)	5
Round Capacity at 45° (in.)	3
Rectangle Capacity at 90° (in.)	5 (H) x 5-3/4 (W) & 2 (H) x 6 (W)
Rectangle Capacity at 45° (in.)	4-1/2 (H) x 3 (W)
Throat Depth (in.)	5
Vertical Worktable (in.)	9-5/8 x 9-1/2
Vise Swivels (deg.)	45
Blade Size (in.)	1/2 x .025 x 64-1/2
Blade Wheel Diameter (in.)	7-3/8
Blade Speed (SFPM)	80, 120, 200
Bed Height (in.)	26
Motor	1/2HP, 115/230V, 1Ph, Prewired 115V
Floor Space Required (in./ L x W x H)	36 x 20 x 39.5
Net Weight (lbs.)	115
OPTIONAL EQUIPMENT	STOCK NUMBER
Replacement Blade - 1/2" x .025" x 64-1/2" x 14R-C	414301

14", 16", 20" AND 36" VERTICAL BANDSAWS

JET's vertical variable speed bandsaws range in capacity of throat depth from 14" to 36", and throat height from 8" to 12". All these saws come standard with a powerful industrial motor and transmission that last for years - even on the job in the most demanding work environments.



COMMON FEATURES

- Heavy-duty completely enclosed steel frame
- Multi-tilting work surfaces
- Easy to read blade tension indicator
- Variable speeds provide proper adjustments for high efficiency cutting

FEATURES OF THE VBS-3612

- Heavy-duty bandsaw can handle large production pieces on its extra large twin tables
- Three wheel system for cutting wide pieces
- Two speed transmission and variable speed allow for wide range of blade speeds

STANDARD EQUIPMENT

- Blade welder, grinder and cutter
- Worklamp
- Chip Blower
- 1/4" x 14/18 VT Bi-Metal blade
- Blade and tire cleaning brush
- Set of tools

ADDITIONAL STANDARD EQUIPMENT FOR THE VBS-3612

- 2 Worktables
- Rip fence

STOCK NUMBER	414483	414485	414482	414470
Model Number	VBS-1408	VBS-1610	VBS-2012	VBS-3612
Blade Speeds (SFPM)	82 - 330	Low 82 - 330, High 985 - 3,950	Low 65 - 555, High 390 - 3,280	Low 50 - 410, High 550 - 5,000
Height Capacity (max./in.)	8	10	12	12
Throat Capacity (max./in.)	14	15-1/2	20	36
Table Size (in.)	20 x 20	22 x 24	24 x 22-1/2	23-5/8 x 27-1/2 and 17-3/4 x 27-1/2
Table Tilt	8° F & B, 12° L, 15° R	8° F & B, 12° L, 15° R	8° F & B, 15° R & 12° L	10° L & 45° R
Blade Length (approx./in.)	114	123-1/2	156-1/2	197
Blade Width (min-max./in.)	1/8 - 1/2	1/8 - 5/8	1/8 - 1	1/8 - 1
Table Height (in.)	39	40	39-1/2	40
Motor	1HP, 115/230V, 1Ph, Prewired 115V	2HP, 230/460V, 3Ph, Prewired 230V	2HP, 230/460V, 3Ph, Prewired 230V	3HP, 230/460V, 3Ph, Prewired 230V
Floor Space Required (in./ L x W x H)	34 x 24 x 68-1/2	37 x 28 x 72-1/2	42 x 30 x 79	69 x 32 x 81
Net Weight (lbs.)	634	944	1,244	1,760

OPTIONAL EQUIPMENT	STOCK NUMBER
VBS-3612 Replacement Blade - 1/4" x .025" x 197" x 14R-C	5674030

18" WOOD / METAL VERTICAL BANDSAW

The JET 18" Vertical Bandsaw handles the workload. An exclusive quick-release T-square style rip fence, built-in cutting height scale and cast iron table are but some of the features on this JET saw that makes all the cuts of its Horizontal counterpart when workspace is at a premium.



FEATURES

- Exclusive quick-release, precision T-square style rip fence
- Built-in cutting height scale
- Convenient speed changes with no tools required
- Extra large 19" x 19" cast iron table
- Ball bearing guide system reduces friction for longer blade life
- Lower blade wheel brush and dust collection port

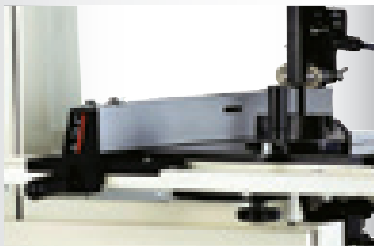

EXCLUSIVE QUICK-RELEASE, PRECISION T-SQUARE STYLE RIP FENCE

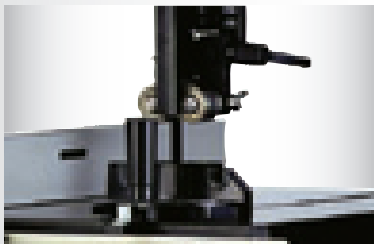

BALL BEARING GUIDE SYSTEM REDUCES FRICTION FOR LONGER BLADE LIFE

STOCK NUMBER	414418
Model Number	VBS-18MW
Height Capacity (max./in.)	12
Throat Depth (max./in.)	18-3/8
Rip left of blade w/fence (max./in.)	16-1/2
Blade Size (in.)	137 x 3/4 x .035
Blade Length (approx./in.)	137
Blade Width (min-max./in.)	1/8 - 1-1/2 (Wood)
Cutting Speeds Wood (SFPM)	1,000, 1,800, 3,200
Cutting Speeds Metal (SFPM)	80, 150, 265
Table Size (in.)	19 x 19
Table Tilt	R 45°, L 10°
Table Height at 90° (in.)	37-1/2
Motor	3/4HP, 115/230V, 1Ph, Prewired 115V
Floor Space Required (in./ L x W x H)	42 x 38 x 74
Net Weight (lbs.)	456

14" WOOD / METAL VERTICAL BANDSAWS

The line of JET 14" Wood/Metal Vertical Bandsaws offers machine and fabrication professionals all the power and precision in a package that meets their individual specifications. An EXCLUSIVE gear box design permits cutting of a great variety of materials. These are everything customers have come to expect from a JET saw, and more.



FEATURES

- Cast iron frame
- Solid one piece steel base for extra stability
- Exclusive gear box design allows wood/metal model saws to be used for a wider variety of metal, wood, non-ferrous metal, plastic cutting applications.
- Conveniently located on/off switch
- Variable speed drive system (J-8201VS & J-8203VS)

STANDARD EQUIPMENT

- Miter gauge
- Dust chute
- Saw blades (wood & metal)
- Adjustable table

STOCK NUMBER	414500K	414504K	414502	414503
Model Number	J-8201K	J-8203K	J-8201VS	J-8203VS
Blade Speeds Metal (SFPM)	39, 57, 78, 107, 142, 196, 278	39, 57, 78, 107, 142, 176, 278	Variable 90-340	Variable 90-340
Blade Speeds Wood (SFPM)	3,300	3,300	2,600	2,600
Under Guide (in.)	6	6	6	6
Under Guide with Riser Block (in.)	12	12	12	12
Height Capacity (max./in.)	6	6	6	6
Throat Capacity (max./in.)	13-1/2	13-1/2	13-1/2	13-1/2
Table Size (in.)	14 x 14	14 x 14	14 x 14	14 x 14
Table Tilt Right	45°	45°	45°	45°
Table Tilt Left	15°	15°	15°	15°
Blade Length (approx./in.)	92-1/2	92-1/2	92-1/2	92-1/2
Blade Width (min-max/in.)	1/8 - 3/4	1/8 - 3/4	1/8 - 3/4	1/8 - 3/4
Miter Gauge Groove Wide x Deep (in.)	3/4 x 3/8	3/4 x 3/8	3/4 x 3/8	3/4 x 3/8
Table Height (in.)	44	44	44	44
Motor	1HP, 115/230V, 1Ph, Prewired 115V	1HP, 230/460V, 3Ph, Prewired 230V	1HP, 115/230V, 1Ph, Prewired 115V	1HP, 230/460V 3Ph, Prewired 230V
Floor Space Required (in./ L x W x H)	26 x 18-1/2 x 67	26 x 18-1/2 x 67	26 x 18-1/2 x 67	26 x 18-1/2 x 67
Net Weight (lbs.)	171	155	325	325

OPTIONAL EQUIPMENT	STOCK NUMBER
Rip Fence — fits all models	5782171
Riser block assembly increases height under the guide by 6" — fits all models	5782181
Replacement Blade - 3/8" x .025" x 92-1/2" x 14R-C	5782722
Replacement Blade - 3/8" x .025" x 92-1/2" x 10R-C	5782723

MANUAL FERROUS COLDSAWS CS AND FK350 SERIES

JET Ferrous Coldsaws deliver clean, burr-free cuts every time. Both the CS and FK350 series offer machine shop and fabrication professionals a list of features and standard design characteristics that make adding a JET a smart choice. The industry-leading Two Year Warranty ensures that JET stands behind these machines.



CS-275

FK350

CS Series FEATURES

- Heavy-duty cast iron frame base standard
- Cast dual pivot saw head
- Hardened and ground worm and wheel gear box
- Two cutting speeds
- 1.3 gallon coolant tank capacity
- Casted blade cover

FK350 FEATURES

- Sturdy gear box design
- Double self centering vise for burr free cuts
- Thermal overload protection with magnetic starter
- 350mm Ferrous cold saw for steel, stainless and tough to cut alloys
- Manually cuts from 45° left to 45° right
- Miter stops at 90°, 45° left to 45° right
- Two cutting speeds
- Casted blade cover

STOCK NUMBER	414226	414227	414214K	414217K
Model Number	CS-275	CS-315	J-FK350-2K	J-FK350-4K
CUTTING CAPACITY FOR TUBING				
Round at 90° (in.)	3-1/8	3-3/8	4-1/2	4-1/2
Round at 45° (in.)	3-1/8	3-3/8	3-1/2	3-1/2
Square at 90° (in.)	2-3/8 x 2-3/8	3-1/16 x 3-1/16	4-1/4	4-1/4
Square at 45° (in.)	2-1/16 x 2-1/16	2-1/4 x 2-1/4	3-1/2	3-1/2
Rectangle at 90° (in.)	3-1/32 x 2	4 x 3-1/16	5-1/2 x 3-3/4	5-1/2 x 3-3/4
Rectangle at 45° (in.)	2-1/16 x 2	3-1/16 x 2-1/4	3-1/2 x 3-1/2	3-1/2 x 3-1/2
CUTTING CAPACITY FOR SOLID				
Round at 90° (in.)	1-3/8	2	2	2
Round at 45° (in.)	1-3/8	2	1-3/4	1-3/4
Square at 90° (in.)	3-1/32 x 2	3-1/16 x 3-1/16	2	2
Square at 45° (in.)	2-1/16 x 2	2-1/4 x 2-1/4	1-3/4	1-3/4
Blade Size (mm)	275 x 32 x 2	315 x 32 x 2	350 x 32 x 2.5	350 x 32 x 2.5
Blade Speeds (RPM)	54, 108	52, 104	44, 88	44, 88
Maximum Vise Opening (in.)	4	4-3/4	6	6
Motor	1.5HP, 230V, 3Ph	2HP, 230V, 3Ph	2HP, 230V, 3Ph	2HP, 460V, 3Ph
Floor Space required (in./ L x W x H)	38 x 37 x 64	39 x 37 x 69	50 x 28 x 60	50 x 28 x 60
Net Weight (lbs.)	350	390	794	794

NON-FERROUS HIGH SPEED MANUAL COLD SAWS

Two cutting speeds, slotting and mitering capabilities and the double, self-centering vise for burr free cuts are just a few of the features that make JET Non-Ferrous High Speed Manual Cold Saws an effective and efficient machine. A rugged design ensures this saw is on the job for years.



FEATURES

- Double self-centering vise for burr-free cuts
- Capable of slotting
- Mitering capabilities – stops at 90°, 45° left and 45° right
- Two cutting speeds
- Includes one high speed NF 350mm blade (579052)
- Casted blade cover

STANDARD EQUIPMENT

- Integral flood-style coolant system
- 30" material length stop
- Safety guards

STOCK NUMBER	414203K	414207K
Model Number	CK350-2K	CK350-4K
CUTTING CAPACITY FOR TUBING		
Round at 90° (in.)	4-1/2	4-1/2
Round at 45° (in.)	3-1/2	3-1/2
Square at 90° (in.)	4-1/4 x 4-1/4	4-1/4 x 4-1/4
Square at 45° (in.)	3-1/2 x 3-1/2	3-1/2 x 3-1/2
Rectangle at 90° (in.)	5-1/2 x 3-3/4	5-1/2 x 3-3/4
Rectangle at 45° (in.)	3-1/2 x 3-1/2	3-1/2 x 3-1/2
CUTTING CAPACITY FOR SOLID		
Round at 90° (in.)	3	3
Round at 45° (in.)	2-1/2	2-1/2
Square at 90° (in.)	3 x 3	3 x 3
Square at 45° (in.)	2-1/2 x 2-1/2	2-1/2 x 2-1/2
Blade Size (mm.)	350 x 32 x 3.4	350 x 32 x 3.4
Blade Speeds (RPM)	1,750, 3,500	1,750, 3,500
Maximum Vise Opening (in.)	6	6
Motor	2HP, 230V, 3Ph	2HP, 460V, 3Ph
Floor Space Required (in./L x W x H)	25 x 52 x 73	25 x 52 x 73
Net Weight (lbs.)	683	683

J-F225 BENCH COLDSAW

The table-top J-F225 Bench Saw enables one to take JET power and precision wherever the job requires. Adjustable depth stop, safety spring loaded trigger switch in the handle and manual vise combine to give this JET saw precision and reliability professionals demand from their machines. Backed by the industry-leading Two Year Warranty, you can have confidence this saw performs cut after cut.



J-F225 FEATURES

- Bronze worm gear and hardened ground worm screw gear box in an oil bath
- Adjustable depth stop
- Blade included
- Manually cuts from 0 - 45° left
- Control handle with a safety spring loaded trigger switch to start or stop the machine
- Coolant system
- Manual vise



LARGE COOLANT TRAY



SPLIT JAW VISE

STOCK NUMBER	414220
Model Number	J-F225
CUTTING CAPACITIES	
Round at 90° (in.)	2-1/2
Round at 45° (in.)	2
Rectangle at 90° (in.)	2-1/2 x 2-15/16
Rectangle at 45° (in.)	1-3/4 x 1-1/4
Square at 90° (in.)	2-1/4
Square at 45° (in.)	1-5/8 x 1-5/8
Blade Size (mm.)	225
Blade Speed (RPM)	52
Motor	1HP, 115V, 1Ph
Floor Space Required (in./ L x W x H)	30 x 17 x 32
Net Weight (lbs.)	84
OPTIONAL EQUIPMENT	
Replacement Blade - 225 - 2 - 32 / 180 Teeth	579000
Replacement Blade - 225 - 2 - 32 / 120 Teeth	579002

CARBIDE TIPPED COLD SAW BLADES FOR NON-FERROUS MATERIALS

90
DAY
WARRANTY

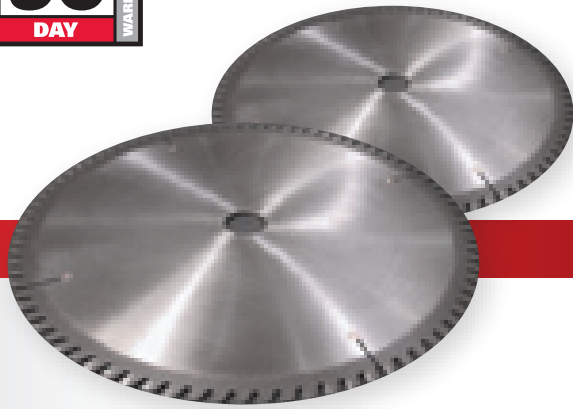

FEATURES

- Three tooth precision tungsten carbide style blades
- General purpose blades
- The 84 teeth blade is for use on medium size solids and extrusions
- The 108 teeth blade is for use on small size solids, tubing and small size extrusions
- These blades are for use on CK High Speed Cold Saws only

STOCK NUMBER	DESCRIPTION
579036	350-2.5-32/360T
579062	350 - 3.4 - 32 / 84 teeth
579064	350 - 3.4 - 32 / 108 teeth
579052	350-3.4-32/180T

MATERIAL SUPPORT STANDS

2
YEAR
WARRANTY



HORIZONTAL

V-ROLLER

FEATURES

- Heavy-duty cast iron and steel construction
- Chrome plated ball bearing roller head
- Locking screws provide added safety
- The roller heads are interchangeable

STOCK NUMBER	414121	414122
Weight Holding Capacity (lbs.)	2,000	2,000
Minimum Stock Diameter (in.)	-	1
Maximum Stock Diameter (in.)	-	12
Length of Horizontal Roller (in.)	14	-
Height Range (in.)	23.5 - 38.5	23.5 - 38.5
Base/3 Legs Area Required (in.)	16.5 x 16.5 Square	16.5 x 16.5 Square
Stand Dimensions (in./ L x W x H)	22 x 22 x 5	22 x 22 x 5
Net Weight (lbs.)	30	30

SAWING HELPFUL INFO

Using the right saw blade is critical to the success of every job. Review the information provided below to equip your JET saws with the proper blade for any job.



CHOOSING A SAW BLADE

A FABRICATION OR METAL SHOP HAS DIVERSE CUTTING REQUIREMENTS, SO CHOOSING THE PROPER BLADES TO SUIT ALL THE REQUIRED APPLICATIONS ON YOUR JET SAW IS VITAL.

You need to ask yourself how can I get the lowest cost per cut while maintaining acceptable levels of surface finish. If you think in these terms, it will be easy to select blades that optimize metal separation productivity and profitability. Fabrication or metal shops use band saws for many different kinds of cutting, including solid materials and heavy-wall tubing, structural shapes, high-efficiency bundle cutting, and hard alloy materials such as tool steels. No one blade is perfect for all of these. After choosing the correct replacement blade for your JET saw, you still have to use it intelligently. Subjecting blades to different types of cutting shortens blade life. Understanding why is the key not only to selecting the right blade, but also to making it last. When blades are used for cutting structural steels or bundles, the teeth are subjected to multiple impacts of different intensities from different directions. In shops, most bandsaw blades fail because of these repeated shocks, not excessive wear. What is most often needed then is a blade design tough enough to withstand these impacts, and still cut at a relatively fast speed while leaving a smooth finish on the product that won't require secondary operations such as filing and grinding. Such blades deliver the lowest cost per cut and by far the best value. Discovering what blade and teeth geometry best fits your usage pattern requires a look at the type and size of equipment, as well as the section sizes and shapes most frequently cut. Most blades used in fabrication are bimetal. These industry workhorses can be configured to withstand the impact punishment delivered in shops that primarily cut shapes and bundles, yet they are hard enough for continuous use with solids and heavy-walled tubing. They can even withstand the wear from the occasional cutting of high-alloy steels.

OTHER PROPERTIES TO CONSIDER:

- Blade width: Use the widest blade your machine will take, except when cutting contours.
- Tooth rake: Select the appropriate rake, or tooth angle, for the materials and shapes to be cut. A positive rake is best for thick solids and heavy-wall tubing. Straight or less positive rakes are preferred for most structural and bundle cutting.
- Tooth shape: Many different tooth shapes are available. A few examples follow:
 - Regular: A conventional tooth used for general-purpose sawing with a straight (zero) rake.
 - Hook: A 10-degree positive rake for fast cutting of nonferrous metals, nonmetallics, plastics, and wood.
 - Skip: A straight (zero) rake with shallow gullets for cutting large sections of soft nonferrous materials, plastics, and wood.
- Pitch: Pitch is defined as the number of teeth within a certain distance (25 mm, or 1 in.) of blade. Cutting thin sections of material requires a fine pitch (more teeth). Thicker sections require more coarse pitches (fewer teeth). Always strive for a minimum of three teeth in the cut. Having six to 12 teeth in the cut at any time is optimal.
- A constant pitch—with all teeth of the blade having a uniform spacing, gullet depth, and rake angle throughout the full length—typically is used for general-purpose cutting. Variable-pitch blades have various tooth sizes and gullet depths to substantially reduce noise and vibration. This helps cut structurals, tubing, and solids smoothly and quickly. Two numbers signifying the lowest/highest pitch on the blade identify this style (for instance, 10/14).

GENERAL BLADE GUIDELINES

GENERAL GUIDELINES TO HELP YOU CHOOSE THE CORRECT BLADE FOR YOUR JET SAW:

CHOOSING THE TPI (Tooth Per Inch):

Choosing the correct TPI (tooth per inch) is very important. The proper TPI varies with the material thickness to be cut. The thinner the material, the finer the pitch. The following are general guidelines to help you choose an appropriate TPI for your application.

- 1/4" or less use a fine pitch of 14/18 TPI.
- 1/4" to 7/16" use 10/14 TPI.
- 7/16" to 9/16" use 8/12 TPI.
- 9/16" to 11/16" use 6/10 TPI.
- 3/4" to 1" use 5/8 TPI.
- 1-2" use 4/6 TPI.
- 2-5" use 3/4 TPI.
- 5-10" use 2/3 TPI.
- 10-20" use 1"/1.5" TPI.
- 20" + use .8/1 TPI.

CHOOSE A LOWER TPI IF SPEED OF CUT IS IMPORTANT, CHOOSE A HIGHER TPI IF FINISH IS MORE IMPORTANT.

- A higher TPI will provide a smoother finish but at a slower pace.
- A lower TPI will provide for faster cuts but with rougher finishes.
- A higher TPI (10/14, 14/18) is recommended for thin cross sections (1/4" & under).
- A lower TPI (3/4, etc.) is recommended for thick cross sections (2" & larger).
- Improper TPI for hard to cut materials will shorten the blade life.
- A tooth pitch that is too high for the cross section will result in chip removal problems, slower cut rates and significantly reduced blade life.
- A tooth pitch that is too low for the cross section tends to produce thick chips, band breakage, stalling in the work piece and tooth stripping/damage.
- As a rule of thumb, a pitch towards the coarse end for a particular cross section is preferable to a pitch that is too fine. Adjustments made to the speed and feed can assist in obtaining the most efficient sawing.
- For bundles, select a slightly lower TPI than appropriate for a single piece.

BLADESAW TERMINOLOGY & BASIC CUTTING SOLUTIONS

Jet strives to make your job easier, by providing you with helpful information on bandsaw blades

BANDSAW BLADE TERMINOLOGY:

- Tooth Form: Straight (constant), Variable, Hook and Skip.
- Tooth Pitch: Distance from one tooth to the next.
- TPI (teeth per inch): ranging from .8-32
- Width: Distance from top of tooth to bottom of blade backing.
- Gage: The thickness of the blade, ie. .025", .035" etc.
- Rake Angle (tooth angle): Standard (0 degree) and Positive (3-12 degree).
- Gullet: The round root portion between the teeth.
- Kerf: The width of cut in the material being sawed. Kerf is a combination of the thickness of the blade plus the width of the tooth set.
- Tooth Set: The tilt of the teeth which provides clearance in the cut. The set to right and left of center is a factor in determining the width of the kerf.
- Raker Set: One tooth tilted left, then right, then straight. Standard design for most applications.
- Wavy Set: Groups of teeth tilting left, then right throughout the blade. Useful when tooth stripping is a problem on thin cross sections such as tubing, sheet stock. These are recommended for light-duty saws.

BASIC CUTTING PROBLEMS / SOLUTIONS:

- Tooth Damage - Blade mounted backwards, teeth in wrong orientation, blade "break-in" insufficient, inappropriate feed/speed, and hardened material.
- Blade Damage - Use higher TPI, lower blade tension, use thinner gage blade, check coolant, inappropriate feed/speed, and check guides.
- Chip welding - tooth size too small, excessive speeds/feeds, insufficient coolant flow.
- The biggest reasons for sawing problems are inappropriate pitch (TPI) and/or improper speeds and feeds for the material type, size and shape being cut. This is especially true when using economy blades of inferior quality. Often, the quality of the chip produced will tell you if you have appropriate speed and feed. Excessive speed and/or too fine of pitch tends to produce a thin, spiral bluish chip and/or cause chip welding. Too low of speed and/or too coarse of pitch tends to cause the teeth to take chunks of material and/or cause tooth breakage and workpiece stalling. When pitch, speeds and feeds are correct, you should see a good quality chip curl with minimal sound and vibration coming from the saw.



TURNING

Precision manufactured to meet the demands of even the highest volume shop, JET's extensive selection of turning machines enable experts to choose the lathes they need for any turning operation. JET turning machines come equipped with the taper attachments, collet closers, digital readouts and accessories the pros need to turn precision parts. Every JET machine is backed by an industry-leading Two Year Warranty. Premier customer support and professional manuals ensure optimal functioning and operation.



PRECISION MANUFACTURED TO MEET YOUR DEMANDS

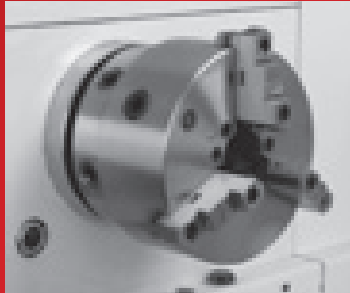

CONTENTS

CNC LATHE	36-37
LARGE SPINDLE BORE LATHES	38-43
GEARED HEAD ENGINE LATHES	44-51
BELT DRIVE LATHES	52-53
ACCESSORIES	54-57
DIGITAL READOUTS	58-59
TURNING HELPFUL INFO	60-61

CL-1640ZX CNC LATHE WITH ANILAM 4200T CONTROL

The Jet ZX CNC lathe takes the best features of our top line manual lathes and adapts the Anilam 4200T CNC system to control the various turning actions. The CNC control is designed for ease of use and intuitive interaction, which means no prior programming experience is needed. A shape Editor allows drawing a part graphically and creating the tool path without programming. A Tool Page provides graphical description of 99 tools, so the operator can specify tool radius, length and wear offsets, etc.



FEATURES

- Anilam 4200T with 12.1 TFT Flat Screen CNC Control
- Dual electronic handwheels for manual control
- Hardened and precision ground bed ways
- High alloy gears hardened, ground and honed
- 3-Bearing spindle support
- Automatic homing
- Easy access chip removal
- 4 Station Programmable Turret
- Automatic lubrication system
- Coolant system with 5.5 gallon coolant tank
- Teach In Mode
- 255 Pairs of Tool Offsets
- Rigid Tapping is Standard
- Turcite B on carriage sliding surfaces

STANDARD EQUIPMENT

- Tool box and tools
- Fully enclosed Cabinet
- 10" 3-jaw chuck
- 16" Face plate
- Steady Rest
- Work light

STOCK NUMBER	320930
Model Number	CL-1640ZX-CNC
Swing over Bed (in.)	16
Swing Through Gap (in.)	25-7/8
Distance Between Centers (in.)	40
Spindle Bore (in.)	3-1/8
Spindle Mount	D1-8
Spindle Taper (w/ Sleeve)	MT-7 (MT-5)
Range of Spindle Speeds (RPM)	80 - 2000
Rapid Feed, X-Axis (in./min.)	394
Rapid Feed, Y-Axis (in./min.)	315
Max Tool Size (in.)	1 x 1
Cross Slide Travel (in.)	9
Carriage Travel (in.)	35
Tailstock Spindle Travel (in.)	6
Taper in Tailstock Spindle	MT-4
Steady Rest Capacity (in.)	3/8 to 7
Width of Bed (in.)	13-1/4
Motor	10HP, 230V, 3Ph
Net Weight (lbs.)	5,680

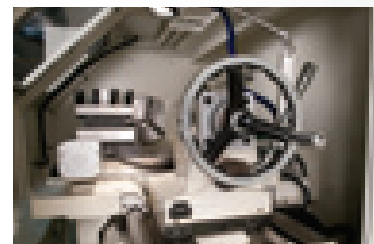

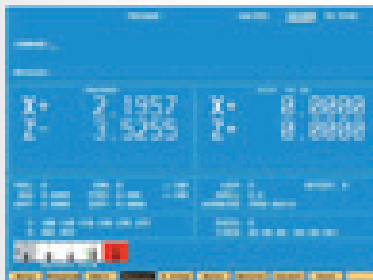

MANUAL MODE:

This lathe operates in manual mode as easily as a conventional lathe; run the axes with up to two hand-wheels. The 4200T is equipped with a number of features and provides the user with a wealth of critical data to ensure superior operation and results.



SEMI-AUTOMATIC MODE:

Operation in dual hand-wheel mode allows the machinist to cut in perfect arcs, tapers and chamfers. As only one hand-wheel is cranked, the 4200T controls both axes to produce the desired shape with exact precision.

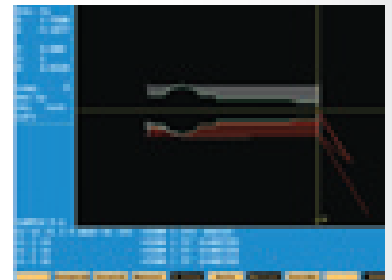

AUTOMATIC MODE:

During automatic operation, the 4200T controls everything from start to finish. The machinist uses several options to generate the program using some very powerful programming tools available to them.

26" LARGE SPINDLE BORE LATHES

The perfect lathe for production use, these new Jet ZH lathes include the best features of our top line manual lathes with many new features and benefits. The GH-2680ZH is a rugged, one piece cast iron base that allows heavy cuts without any flexing. Backed by an industry-leading Two Year Warranty.



FEATURES

- Large 4-1/8" Spindle Bore
- Clutch operated headstock with all headstock gears hardened and ground
- Rapid power traverse on cross slide and carriage
- Headstock-gearbox designed for quick setup of thread turning operation without changing gears.
- Bed ways are induction hardened and ground for durability
- Heavy-duty tailstock and quill
- One piece heavy-duty cast iron base and bed for GH-2680ZH

STANDARD EQUIPMENT

- Drive Plate
- 12" 3-jaw direct mount scroll chuck with top reversing jaws
- 16" 4-jaw chuck
- Face Plate
- 2 Steady Rests
- Follow Rest
- 4 Way tool post
- Micro-carriage bed stop
- Coolant System
- Full length splash guard for GH-2680ZH, moveable splash guard for GH-26120ZH
- Halogen work lamp

LARGE SPINDLE BORE LATHE AND ACCESSORY PACKAGES INSTALLED

26X80" Geared Head Engine Lathe with Newall DP700 DRO	321861
26X120" Geared Head Engine Lathe with Taper Attachment	321893
26X120" Geared Head Engine Lathe with Newall DP700 DRO	321891
26x120" Geared Head Engine Lathe with Newall DP700 DRO and Taper Attachment	321894

OPTIONAL EQUIPMENT	STOCK NUMBER
Taper Attachment	321293

STOCK NUMBER	321860	321890
Max. swing over bed (in.)	26	26
Max. swing over cross slide (in.)	16.5	16.5
Swing Through Gap (in.)	34	34
Length of Gap (in.)	8	8
Distance between Centers (in.)	80	120
Hole Through Spindle (in.)	4-1/8	4-1/8
Spindle Mount	D1-8	D1-8
Spindle Taper	MT-5	MT-5
Number of Spindle Speeds	12	12
Range of Spindle Speeds (RPM)	36-1,600	36-1,600
Number of Longitudinal Feeds (in.)	65	65
Range of Longitudinal Feeds (Inch/rev)	.0023-.0937	.0023-.0937
Number of Cross Feeds	63	63
Range of Cross Feeds (Inch/rev)	.0010-.0404	.0040-.0404
Number of Inch Threads	48	48
Range of Inch Threads	2-30	2-30
Number of Metric Threads	22	22
Range of Metric Threads (mm)	1-14	1-14
Number of D.P Threads	24	24
Range of D.P Threads	4-56 DPI	4-56 DPI
Number of Module Threads	18	18
Range of Module Threads (mm)	0.5-7	0.5-7
Max. Tool Size	1-1/4 x 1-1/4	1-1/4 x 1-1/4
Max. Compound Slide Travel (in.)	5-1/2	5-1/2
Max. Cross Slide Travel (in.)	12-3/32	12-3/32
Max. Carriage Travel (in.)	72-1/2	108-1/4
Tailstock Spindle Travel (in.)	6	6
Taper in Tailstock Spindle	MT-5	MT-5
Follow Rest Capacity	25/32 - 3-15/16	25/32 - 3-15/16
Steady Rest Capacity -Small	25/32 - 4-29/32	25/32 - 4-29/32
Steady Rest Capacity -Large	3-15/16 - 9-7/16	3-15/16 - 9-7/16
Width of Bed (in.)	16	16
Coolant Pump System	1/8HP	1/8HP
Main Motor	10HP, 230/460V, 3Ph	10HP, 230/460V, 3Ph
Prewired	230V	230V
Net Weight (lbs)	8514	9362
Overall Dimensions (LxWxH/Inch)	138 x 43 x 57	178 x 43 x 57

321860

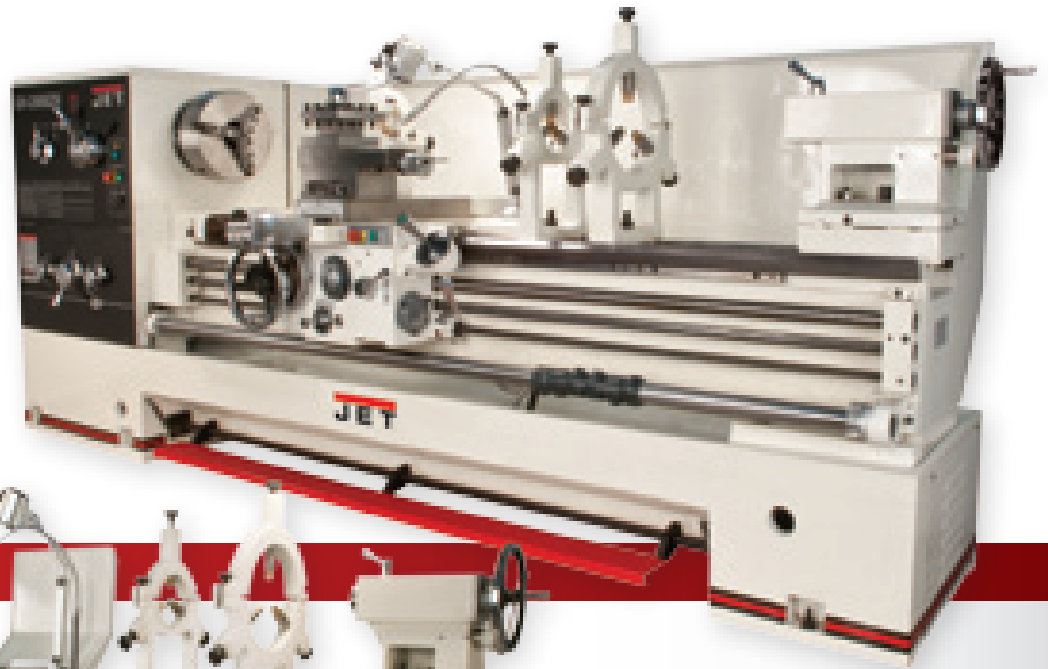

321890

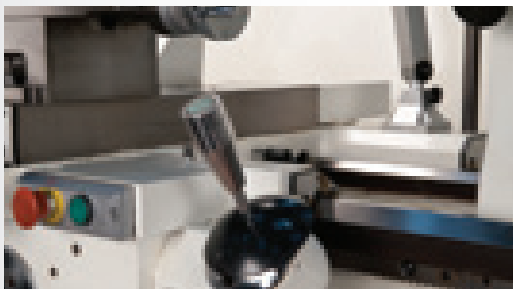
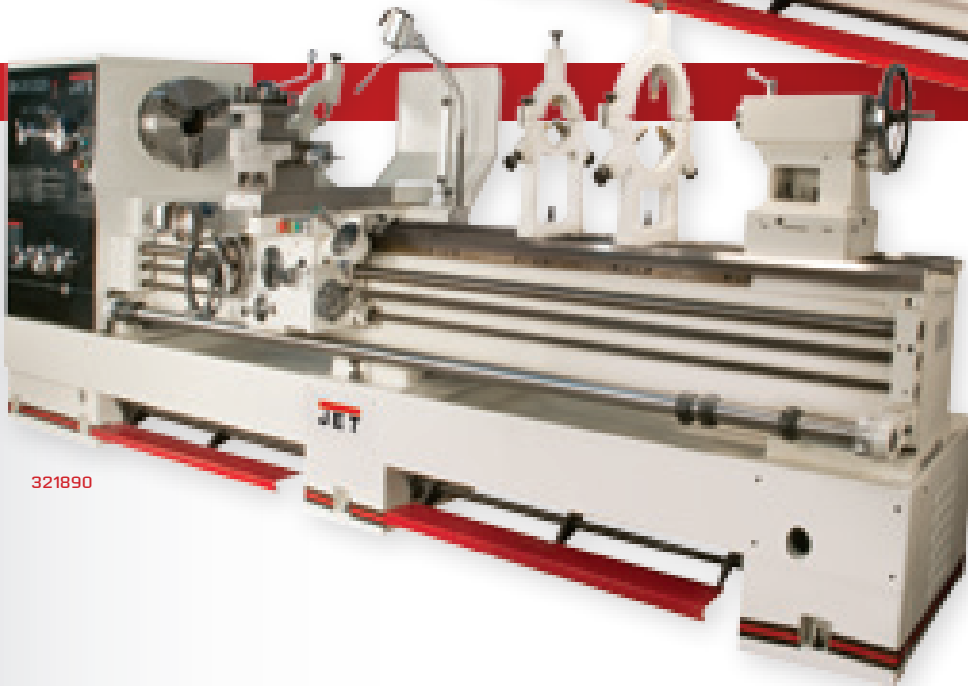

RAPID TRAVERSE:

The rapid power traverse on the cross slide and carriage is a great addition to these lathes that allows the user to access the work piece quickly. The joy stick design enhances overall ergonomics.



LARGE 4-1/8" SPINDLE BORE

ZX SERIES 14" - 22" LARGE SPINDLE BORE LATHES

A JET exclusive design, the ZX Large Spindle Bore Lathe Series provides power, precision, efficiency and reliability to your metal shop. A one piece cast iron base absorbs vibrations during operation to allow heavier cuts and ensure accuracy throughout, and the Universal Gearbox eliminates the need to change gears. A loaded standard equipment package makes the ZX lathes the model of production proficiency.



FEATURES

- 3-1/8" bore spindle is supported by two tapered and one ball bearing
- Universal gearbox allows inch, metric, diametral, and module pitch threads, no change gears required
- One-piece cast iron base absorbs vibration allowing heavier cuts
- High quality ANSI Class 50 wear-resistant cast iron bed ways are hardened and ground
- Front Removable Chip Tray
- Large easy to use foot brake
- Chrome molybdenum headstock gears are hardened, ground, and shaved
- Carriage features one-shot lubrication and Turcite B on bed sliding surfaces
- T-slotted compound slide featuring a four-way tool post
- Removable gap allows up to 25-7/8" diameter work on 16", 27-1/2" on 18"
- Five position automatic carriage stop increases productivity
- Attractive chrome control levers, dials, and knobs complete this impressive package

STANDARD EQUIPMENT

- 10" 3-jaw scroll chuck with top reversing jaws
- 12" 4-jaw independent chuck
- 12" face plate (16" models)
- 16" face plate (18" models)
- Four-way tool post
- Follow rest
- Large capacity steady rest
- Fully integrated coolant system
- Full length splash guard and coolant return
- Chuck Guard
- Articulating halogen work lamp
- Centrally located controls with jog button
- Threading dial
- Mounting pads and levelers
- Spindle sleeve (MT-7 to MT-5)
- Live center
- Tolerance test certificate
- Tool box and adjusting tools

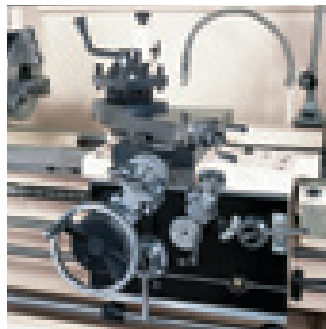

CARRIAGE FEATURES ONE-SHOT LUBRICATION AND TURCITE B ON SLIDING SURFACES

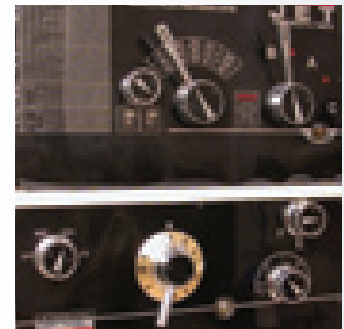

ATTRACTIVE CHROME CONTROL LEVERS, DIALS AND KNOBS COMPLETE THIS PACKAGE



CLEAN, SIMPLE DESIGN AND WELL MARKED ELECTRICS MAKE MAINTENANCE ON THESE LATHES EASY!



LARGE 3-1/8" SPINDLE BORE



EVERY JET ZX LATHE COMES WITH A FOUR-WAY TOOL POST

OPTIONAL EQUIPMENT	STOCK NUMBER
5C Lever-Type Collet Closer	321292
Taper Attachment	321291



321910

STOCK NUMBER	321910	321920	321930	321940	321950	321960	321970	321980
Model Number	GH-1440ZX	GH-1460ZX	GH-1640ZX	GH-1660ZX	GH-1840ZX	GH-1860ZX	GH-1880ZX	GH-2280ZX
Swing over Bed (in.)	14	14	16	16	18	18	18	22
Swing over Cross Slide (in.)	7-5/8	7-5/8	10	10	11	11	11	13
Swing Through Gap (in.)	18	18	25-1/2	25-1/2	27-1/2	27-1/2	27-1/2	29-1/2
Length of Gap (in.)	12	12	12	12	12	12	12	12
Distance Between Centers (in.)	40	60	40	60	40	60	80	80
Spindle Bore (in.)	3-1/8	3-1/8	3-1/8	3-1/8	3-1/8	3-1/8	3-1/8	3-1/8
Spindle Mount	D1-8	D1-8	D1-8	D1-8	D1-8	D1-8	D1-8	D1-8
Spindle Taper (w/ Sleeve)	MT-7 (MT-5)	MT-7 (MT-5)	MT-7 (MT-5)	MT-7 (MT-5)	MT-7 (MT-5)	MT-7 (MT-5)	MT-7 (MT-5)	MT-7(MT-5)
Number of Spindle Speeds	12	12	12	12	12	12	12	12
Range of Spindle Speeds (RPM)	42 - 1,800	42 - 1,800	25 - 1,800	25 - 1,800	25 - 1,800	25 - 1,800	25 - 1,800	25 - 1,800
Number of Longitudinal and Cross Feed Rates	122	122	122	122	122	122	122	122
Range of Longitudinal Feeds (IPR)	.0015 - .0913	.0015 - .0913	.0015 - .0913	.0015 - .0913	.0015 - .0913	.0015 - .0913	.0015 - .0913	.0015 - .0913
Range of Cross Feeds (IPR)	.0006 - .0365	.0006 - .0365	.0006 - .0365	.0006 - .0365	.0006 - .0365	.0006 - .0365	.0006 - .0365	.0006 - .0365
Number of Inch Threads	61	61	61	61	61	61	61	61
Range of Inch Threads (TPI)	1-5/8 - 72	1-5/8 - 72	1-5/8 - 72	1-5/8 - 72	1-5/8 - 72	1-5/8 - 72	1-5/8 - 72	1-5/8 - 72
Number of Metric Threads	24	24	24	24	24	24	24	24
Range of Metric Threads	.05 - 20	.05 - 20	.05 - 20	.05 - 20	.05 - 20	.05 - 20	.05 - 20	.05 - 20
Max Tool Size (in.)	1 x 1	1 x 1	1 x 1	1 x 1	1 x 1	1 x 1	1 x 1	1 x 1
Compound Slide Travel (in.)	5-1/8	5-1/8	5-1/8	5-1/8	5-1/8	5-1/8	5-1/8	5-1/8
Cross Slide Travel (in.)	9	9	9	9	9	9	9	12
Carriage Travel (in.)	36-9/16	55-9/16	36-9/16	55-9/16	36-9/16	55-9/16	74-5/16	74-5/16
Tailstock Spindle Travel (in.)	5	5	5	5	5	5	5	5
Taper in Tailstock Spindle	MT-4	MT-4	MT-4	MT-4	MT-5	MT-5	MT-5	MT-5
Steady Rest Capacity (in.)	3/8 to 7	3/8 to 7	3/8 to 7	3/8 to 7	3/8 to 7-3/4	3/8 to 7-3/4	3/8 to 7-3/4	3/8 to 7-3/4
Follow Rest Capacity (in.)	1/2 - 3-1/2	1/2 - 3-1/2	1/2 - 3-1/2	1/2 - 3-1/2	1/2 - 3-1/2	1/2 - 3-1/2	1/2 - 3-1/2	1/2 - 3-1/2
Width of Bed (in.)	13-1/8	13-1/8	13-1/8	13-1/8	13-1/8	13-1/8	13-1/8	13-1/8
Overall Dimensions (in./ L x W x H)	96 x 44 x 66	116 x 44 x 66	96 x 44 x 66	115 x 44 x 66	96 x 44 x 66	115 x 44 x 66	136 x 44 x 66	136 x 45 x 71
Motor	7-1/2HP, 3Ph, 230V/460V Prewired 230V	7-1/2HP, 3Ph, 230/460V Prewired 230V	7-1/2HP, 230/460V, 3Ph, Prewired 230V	7-1/2HP, 230/460V, 3Ph, Prewired 230V	7-1/2HP, 230/460V, 3Ph, Prewired 230V	7-1/2HP, 230/460V, 3Ph, Prewired 230V	7-1/2HP, 230/460V, 3Ph, Prewired 230V	10HP, 230/460V, 3Ph, Prewired 230V
Net Weight (lbs.)	5,187	5,380	5,475	5,795	5,980	6,245	6,590	6,933

ZX SERIES 14" - 22" LARGE SPINDLE BORE LATHES PACKAGES

JET will customize your machine anyway you need it. We factory install DRO's, Collet Closer, Taper Attachments or any mixture to fit your shop's needs.

**CONTACT CUSTOMER SERVICE AT
888-804-7129 FOR ADDITIONAL
CUSTOMIZED PACKAGES**

GH-1440ZX LATHE AND ACCESSORY PACKAGES INSTALLED	
GH-1440ZX with Taper Attachment	321467
GH-1440ZX with Collet Closer	321531
GH-1440ZX with Acu-Rite 200S 2 Axis DRO	321469
GH-1440ZX with Acu-Rite 200S 2 Axis DRO & Taper Attachment	321507
GH-1440ZX with Acu-Rite 200S 2 Axis DRO & Collet Closer	321501
GH-1440ZX with Acu-Rite 200S 2 Axis DRO, Taper Attachment & Collet Closer	321569
GH-1440ZX with Acu-Rite 300S 2 Axis DRO	321301
GH-1440ZX with Acu-Rite 300S 2 Axis DRO & Taper Attachment	321303
GH-1440ZX with Acu-Rite 300S 2 Axis DRO & Collet Closer	321304
GH-1440ZX with Acu-Rite 300S 2 Axis DRO, Taper Attachment & Collet Closer	321302
GH-1440ZX with Newall DP700 2-Axis DRO	321470
GH-1440ZX with Newall DP700 2-Axis DRO & Taper Attachment	321570
GH-1440ZX with Newall DP700 2-Axis DRO & Collet Closer	321441
GH-1440ZX with Newall DP700 2-Axis DRO, Collet Closer & Taper Attachment	321498
GH-1460ZX LATHE AND ACCESSORY PACKAGES INSTALLED	
GH-1460ZX with Taper Attachment	321480
GH-1460ZX with Acu-Rite 200S 2 Axis DRO	321478
GH-1460ZX with Acu-Rite 200S 2 Axis DRO & Taper Attachment	321503
GH-1460ZX with Acu-Rite 200S 2 Axis DRO & Collet Closer	321490
GH-1460ZX with Acu-Rite 200S 2 Axis DRO, Taper Attachment & Collet Closer	321509
GH-1460ZX with Acu-Rite 300S 2 Axis DRO	321311
GH-1460ZX with Acu-Rite 300S 2 Axis DRO & Taper Attachment	321312
GH-1460ZX with Acu-Rite 300S 2 Axis DRO & Collet Closer	321315
GH-1460ZX with Acu-Rite 300S 2 Axis DRO, Taper Attachment & Collet Closer	321313
GH-1460ZX with Newall DP700 2-Axis DRO	321137
GH-1460ZX with Newall DP700 2-Axis DRO & Collet Closer	321585

GH-1640ZX LATHE AND ACCESSORY PACKAGES INSTALLED	
GH-1640ZX with Taper Attachment	321474
GH-1640ZX with Collet Closer	321439
GH-1640ZX with Acu-Rite 200S 2 Axis DRO	321475
GH-1640ZX with Acu-Rite 200S 2 Axis DRO & Taper Attachment	321508
GH-1640ZX with Acu-Rite 200S 2 Axis DRO & Collet Closer	321495
GH-1640ZX with Acu-Rite 200S 3- Axis DRO	321525
GH-1640ZX with Acu-Rite 300S 2 Axis DRO	321381
GH-1640ZX with Acu-Rite 300S 2 Axis DRO & Taper Attachment	321382
GH-1640ZX with Acu-Rite 300S 2 Axis DRO & Collet Closer	321383
GH-1640ZX with Newall DP700 2-Axis DRO	321138
GH-1640ZX with Newall DP700 2-Axis DRO & Taper Attachment	321148
GH-1640ZX with Newall DP700 2-Axis DRO & Collet Closer	321494
GH-1640ZX with Newall DP700 2-Axis DRO, Collet Closer & Taper Attachment	321147
GH-1660ZX LATHE AND ACCESSORY PACKAGES INSTALLED	
GH-1660ZX with Taper Attachment	321477
GH-1660ZX with Collet Closer	321573
GH-1660ZX with Taper Attachment & Collet Closer	321544
GH-1660ZX with Acu-Rite 200S 2 Axis DRO	321455
GH-1660ZX with Acu-Rite 200S 2 Axis DRO & Taper Attachment	321543
GH-1660ZX with Acu-Rite 200S 2 Axis DRO & Collet Closer	321440
GH-1660ZX with Acu-Rite 200S 2 Axis DRO, Taper Attachment & Collet Closer	321576
GH-1660ZX with Acu-Rite 200S 3- Axis DRO	321530
GH-1660ZX with Acu-Rite 300S 2 Axis DRO	321388
GH-1660ZX with Acu-Rite 300S 2 Axis DRO & Taper Attachment	321389
GH-1660ZX with Acu-Rite 300S 2 Axis DRO & Collet Closer	321390
GH-1660ZX with Acu-Rite 300S 2 Axis DRO, Taper Attachment & Collet Closer	321391
GH-1660ZX with Newall DP700 2-Axis DRO	321139
GH-1660ZX with Newall DP700 2-Axis DRO & Taper Attachment	321529
GH-1660ZX with Newall DP700 2-Axis DRO & Collet Closer	321527
GH-1660ZX with Newall DP700 2-Axis DRO, Collet Closer & Taper Attachment	321502



NEWALL DP700 - DRO

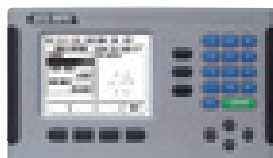

ACU-RITE 200S - DRO

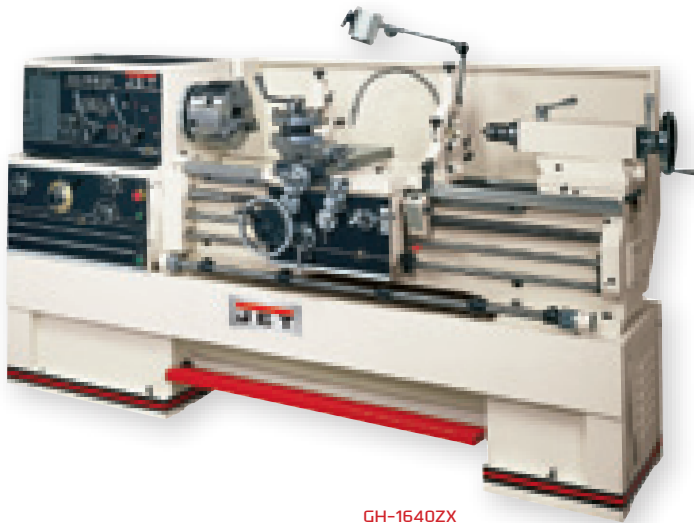

GH-1640ZX



GH-1440ZX

GH-1840ZX LATHE AND ACCESSORY PACKAGES INSTALLED

GH-1840ZX with Taper Attachment	321466
GH-1840ZX with Acu-Rite 200S 2 Axis DRO	321481
GH-1840ZX with Acu-Rite 200S 2 Axis DRO & Taper Attachment	321483
GH-1840ZX with Acu-Rite 200S 2 Axis DRO & Collet Closer	321448
GH-1840ZX with Acu-Rite 200S 2 Axis DRO, Taper Attachment & Collet Closer	321454
GH-1840ZX with Acu-Rite 300S 2 Axis DRO	321415
GH-1840ZX with Acu-Rite 300S 2 Axis DRO & Taper Attachment	321418
GH-1840ZX with Acu-Rite 300S 2 Axis DRO & Collet Closer	321416
GH-1840ZX with Acu-Rite 300S 2 Axis DRO, Taper Attachment & Collet Closer	321417
GH-1840ZX with Newall DP700 2-Axis DRO	321650
GH-1840ZX with Newall DP700 2-Axis DRO & Collet Closer	321655
GH-1840ZX with Newall DP700 2-Axis DRO, Collet Closer & Taper Attachment	321657

GH-1860ZX LATHE AND ACCESSORY PACKAGES INSTALLED

GH-1860ZX with Taper Attachment	321463
GH-1860ZX with Taper Attachment & Collet Closer	321961
GH-1860ZX with Acu-Rite 200S 2 Axis DRO	321484
GH-1860ZX with Acu-Rite 200S 2 Axis DRO & Taper Attachment	321504
GH-1860ZX with Acu-Rite 200S 2 Axis DRO & Collet Closer	321491
GH-1860ZX with Acu-Rite 200S 2 Axis DRO, Taper Attachment & Collet Closer	321505
GH-1860ZX with Acu-Rite 300S 2 Axis DRO	321590
GH-1860ZX with Acu-Rite 300S 2 Axis DRO & Taper Attachment	321591
GH-1860ZX with Acu-Rite 300S 2 Axis DRO & Collet Closer	321592
GH-1860ZX with Acu-Rite 300S 2 Axis DRO, Taper Attachment & Collet Closer	321593
GH-1860ZX with Newall DP700 2-Axis DRO	321485
GH-1860ZX with Newall DP700 2-Axis DRO & Taper Attachment	321452
GH-1860ZX with Newall DP700 2-Axis DRO, Collet Closer & Taper Attachment	321557

GH-1880ZX LATHE AND ACCESSORY PACKAGES INSTALLED

GH-1880ZX with Taper Attachment	321486
GH-1880ZX with Taper Attachment & Collet Closer	322486
GH-1880ZX with Acu-Rite 200S 2 Axis DRO	321487
GH-1880ZX with Acu-Rite 200S 2 Axis DRO & Taper Attachment	321560
GH-1880ZX with Acu-Rite 200S 2 Axis DRO & Collet Closer	321492
GH-1880ZX with Acu-Rite 200S 2 Axis DRO, Taper Attachment & Collet Closer	321493
GH-1880ZX with Acu-Rite 300S 2 Axis DRO	321595
GH-1880ZX with Acu-Rite 300S 2 Axis DRO & Taper Attachment	321597
GH-1880ZX with Acu-Rite 300S 2 Axis DRO & Collet Closer	321598
GH-1880ZX with Acu-Rite 300S 2 Axis DRO, Taper Attachment & Collet Closer	321599
GH-1880ZX with Newall DP700 2-Axis DRO	321488
GH-1880ZX with Newall DP700 2-Axis DRO & Taper Attachment	321571

GH-2280ZX LATHE AND ACCESSORY PACKAGES INSTALLED

GH-2280ZX with Taper Attachment	321565
GH-2280ZX with Collet Closer	321496
GH-2280ZX with Taper Attachment & Collet Closer	321575
GH-2280ZX with Acu-Rite 200S 2 Axis DRO	321879
GH-2280ZX with Acu-Rite 200S 2 Axis DRO & Taper Attachment	321567
GH-2280ZX with Acu-Rite 200S 2 Axis DRO & Collet Closer	321566
GH-2280ZX with Acu-Rite 200S 2 Axis DRO, Taper Attachment & Collet Closer	321568
GH-2280ZX with Acu-Rite 300S 2 Axis DRO	321610
GH-2280ZX with Acu-Rite 300S 2 Axis DRO & Taper Attachment	321612
GH-2280ZX with Acu-Rite 300S 2 Axis DRO & Collet Closer	321613
GH-2280ZX with Acu-Rite 300S 2 Axis DRO, Taper Attachment & Collet Closer	321615
GH-2280ZX with Newall DP700 2-Axis DRO	321880
GH-2280ZX with Newall DP700 2-Axis DRO & Taper Attachment	321881
GH-2280ZX with Newall DP700 2-Axis DRO, Collet Closer & Taper Attachment	321579

16" x 40" ZK GEARED HEAD ENGINE LATHE

This new JET GH1640-ZK lathe takes the best features of our ZX series manual lathes scaled down with a 2" Spindle Bore, which makes it perfect for Small Machine and Maintenance Shops or just about anywhere you might do turning.

The headstock gearbox is designed for quick setup of threading without any gear changes, all this is done with the dials on the front of the lathe.

Equipped with a one piece casting that allows for heavy cutting without any flexing.



FEATURES

- Chrome Molybdenum headstock gears are hardened and ground
- Universal Gearbox allows inch, metric, diametral and module pitch threads without changing gears
- High quality ANSI Class 50 wear-resistant bed ways are hardened and ground
- Removable Gap allows up to 23-5/8" diameter workpiece
- Attractive chrome-plated control levers, dials and knobs complete this impressive package
- D1-6 spindle is precisely ground for accuracy and supported by high quality spindle bearings
- Large easy to use foot brake

STANDARD EQUIPMENT

- 8" 3-Jaw Chuck with top reversing jaws
- 10" 4-Jaw Chuck
- 12" Face Plate
- Follow Rest & Steady Rest
- Fully integrated coolant system
- Full length splash guard
- Micro-carriage stops
- Carriage-mounted spindle control
- Removable Chip Tray in the front of stand
- 4-Way Tool Post
- Articulating halogen work lamp
- Mounting pads and levers

STOCK NUMBER	321850
Model Number	GH-1640ZK
Swing over Bed (in.)	16
Swing over Cross Slide (in.)	10
Swing Through Gap (in.)	23-5/8
Length of Gap (in.)	10-5/8
Distance between Centers (in.)	40
Hole Through Spindle (in.)	2
Spindle Mount	D1-6
Spindle Taper (w/ Sleeve)	MT-6 (MT-4)
Number of Spindle Speeds	12
Range of Spindle Speeds (RPM)	42-1,800
Number of Longitudinal and Cross Feed Rates	122
Range of Longitudinal Feeds (IPR)	.0015-.0913
Range of Cross Feeds (IPR)	.0006-.0365
Number of Inch Threads	61
Range of Inch Threads (TPI)	1-5/8-72 TPI
Number of Metric Threads	24
Range of Metric Threads	0.5 - 20
Max.Tool Size (in.)	1 x 1
Compound Slide Travel (in.)	5-1/8
Cross Slide Travel (in.)	10-13/16
Carriage Travel (in.)	36-3/8
Tailstock Spindle Travel (in.)	6
Taper in Tailstock Spindle	MT-4
Steady Rest Capacity (in.)	7/16 - 3-15/16
Follow Rest Capacity (in.)	1/2 - 3-1/8
Width of Bed (in.)	12-1/4
Overall Dimensions (in./ L x W x H)	91x42-1/8x49
Coolant Pump System	1/8HP, 3Ph
Motor:	2 Speed, 230/460V, 3Ph
High Speed	7-1/2HP
Low Speed	5HP
Prewired	230V
Net Weight (lbs)	3,877

ZK GEARED HEAD ENGINE LATHE AND ACCESSORY PACKAGES INSTALLED

GH-1640ZK Lathe with Taper Attachment	321852
GH-1640ZK Lathe with DP700 DRO & Taper Attachment	321851



6" 3-JAW DIRECT MOUNT SCROLL CHUCK

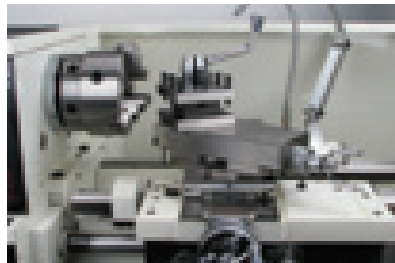

4-WAY TOOLPOST



HEADSTOCK



THREADING DIAL

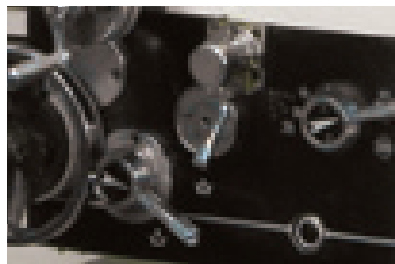

ADJUSTABLE FEED CLUTCH



MICRO-CARRIAGE STOP

13" x 40" AND 14" x 40" GEARED HEAD ENGINE LATHES

Unique JET exclusive design, this machine is considered by many a leader among Geared Head Engine Lathes. The features enable high-volume, precision use under even the strictest of specifications. The GH-1340W and 1440W embody versatility, accuracy, durability and efficiency.



FEATURES

- Hardened and ground gears are featured in the headstock and gearbox
- D1-4 spindle is precision ground for accuracy and supported by high-quality tapered roller bearings
- Splined, not keyed, shafts are utilized in the headstock
- Spindle actuation control is apron mounted
- Headstock is constantly oiled during operation
- V-way bed design is induction hardened and ground
- Gap bed section provided for larger diameter work
- Independent leadscrew and feed rod
- Inch-metric dials are standard
- Compound and cross slide have backlash adjustment
- Adjustable gibs are incorporated in the carriage and slideways
- Tailstock may be offset for turning tapers and includes an inch-metric graduated quill
- Tolerance test certificate included

STANDARD EQUIPMENT

- Micro-carriage bed stop
- Front removable chip tray
- Heavy-duty Stand
- 6" 3-jaw direct mount scroll chuck with top reversing jaws
- 8" 4-jaw independent chuck
- 12" face plate
- Four-way tool post
- Steady and follow rest
- Spindle jog button
- Foot brake
- Chuck Guard
- Coolant system with splash guard
- Metric change gears
- Halogen work lamp

STOCK NUMBER	321810/321820	321830/321840
Model Number	GH-1340W-1 GH-1340W-3	GH-1440W-1 GH-1440W-3
Swing over Bed (in.)	13	14
Swing over Cross Slide (in.)	7-1/4	8-1/4
Swing Through Gap (in.)	19	20
Length of Gap (in.)	9-3/8	9-3/8
Distance Between Centers (in.)	40	40
Spindle Bore (in.)	1-1/2	1-1/2
Spindle Mount	D1-4	D1-4
Spindle Taper (w/ Sleeve)	MT-5 (MT-3)	MT-5 (MT-3)
Number of Spindle Speeds	12	12
Range of Spindle Speeds (RPM)	40 - 1,800	40 - 1,800
Number of Longitudinal and Cross Feed Rates	40	40
Range of Longitudinal Feeds (IPR)	0.0011 - 0.0271	0.0011 - 0.0271
Range of Cross Feeds (IPR)	0.0003 - 0.0103	0.0003 - 0.0103
Number of Inch Threads	40	40
Range of Inch Threads (TPI)	4 - 112	4 - 112
Number of Metric Threads	22	22
Range of Metric Threads	0.45 - 7.5	0.45 - 7.5
Max Tool Size (in.)	5/8 x 5/8	5/8 x 5/8
Compound Slide Travel (in.)	3-1/2	3-1/2
Cross Slide Travel (in.)	6-3/8	6-3/8
Carriage Travel (in.)	37-1/2	37-1/2
Tailstock Spindle Travel (in.)	4-3/4	4-3/4
Taper in Tailstock Spindle	MT-3	MT-3
Steady Rest Capacity (in.)	3-1/2	3-1/2
Follow Rest Capacity (in.)	2-3/4	2-3/4
Width of Bed (in.)	10-1/4	10-1/4
Overall Dimensions (in./ L x W x H)	78 x 38 x 59	78 x 38 x 59
Motor: Stock Number 321810/321830	3HP, 1Ph, 230V	3HP, 1Ph, 230V
Motor: Stock Number 321820/321840	3HP, 3Ph, 230/460V Prewired 230V	3HP, 3Ph, 230V/460V Prewired 230V
Net Weight (lbs.)	2,081	2,191



321810



FRONT REMOVABLE CHIP TRAY



COMPOUND AND CROSS SLIDE HAVE BACKLASH ADJUSTMENT



EASY TO REACH EMERGENCY STOP

13" x 40" AND 14" x 40" GEARED HEAD ENGINE LATHES PACKAGES

JET will custom fit your Geared Head Engine Lathe with the combination of features and accessories best suited to meet the demands of your operation.

**CONTACT CUSTOMER SERVICE AT
888-804-7129 FOR ADDITIONAL
CUSTOMIZED PACKAGES**

GHB-1340W-1 LATHE AND ACCESSORY PACKAGES INSTALLED	
GH-1340W-1 with Taper Attachment	321521
GH-1340W-1 with Collet Closer	321151
GH-1340W-1 with Taper Attachment & Collet Closer	321160
GH-1340W-1 with Acu-Rite VUE 2 Axis DRO	321401
GH-1340W-1 with Acu-Rite VUE 2 Axis DRO & Taper Attachment	321425
GH-1340W-1 with Acu-Rite VUE 2 Axis DRO & Collet Closer	321146
GH-1340W-1 with Acu-Rite VUE 2 Axis DRO, Taper Attachment & Collet Closer	321126
GH-1340W-1 with Acu-Rite 200S 2 Axis DRO	321532
GH-1340W-1 with Acu-Rite 200S 2 Axis DRO & Taper Attachment	321128
GH-1340W-1 with Acu-Rite 200S 2 Axis DRO & Collet Closer	321526
GH-1340W-1 with Acu-Rite 200S 2 Axis DRO, Taper Attachment & Collet Closer	321538
GH-1340W-1 with Newall DP700 2-Axis DRO	321132
GH-1340W-1 with Newall DP700 2-Axis DRO & Taper Attachment	321154
GH-1340W-1 with Newall DP700 2-Axis DRO & Collet Closer	321142

GHB-1340W-3 LATHE AND ACCESSORY PACKAGES INSTALLED	
GH-1340W-3 with Taper Attachment	321516
GH-1340W-3 with Collet Closer	321555
GH-1340W-3 with Taper Attachment & Collet Closer	321577
GH-1340W-3 with Acu-Rite VUE 2 Axis DRO	321402
GH-1340W-3 with Acu-Rite VUE 2 Axis DRO & Taper Attachment	321172
GH-1340W-3 with Acu-Rite VUE 2 Axis DRO & Collet Closer	321170
GH-1340W-3 with Acu-Rite 200S 2 Axis DRO	321459
GH-1340W-3 with Acu-Rite 200S 2 Axis DRO & Taper Attachment	321447
GH-1340W-3 with Acu-Rite 200S 2 Axis DRO & Collet Closer	321562
GH-1340W-3 with Acu-Rite 200S 2 Axis DRO, Taper Attachment & Collet Closer	321546
GH-1340W-3 with Newall DP700 2-Axis DRO	321133
GH-1340W-3 with Newall DP700 2-Axis DRO & Taper Attachment	321143
GH-1340W-3 with Newall DP700 2-Axis DRO & Collet Closer	321537
GH-1340W-3 with Newall DP700 2-Axis DRO, Collet Closer & Taper Attachment	321547



NEWALL DP700 - DRO

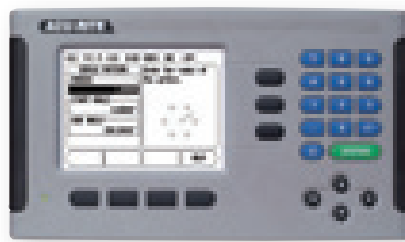

ACU-RITE 200S - DRO



VUE ACU-RITE DRO



GH-1440W-1 LATHE AND ACCESSORY PACKAGES INSTALLED

GH-1440W-1 with Taper Attachment	321517
GH-1440W-1 with Collet Closer	321518
GH-1440W-1 with Taper Attachment & Collet Closer	321500
GH-1440W-1 with Acu-Rite VUE 2 Axis DRO	321403
GH-1440W-1 with Acu-Rite VUE 2 Axis DRO & Taper Attachment	321175
GH-1440W-1 with Acu-Rite VUE 2 Axis DRO & Collet Closer	321173
GH-1440W-1 with Acu-Rite 200S 2 Axis DRO	321549
GH-1440W-1 with Acu-Rite 200S 2 Axis DRO & Taper Attachment	321550
GH-1440W-1 with Acu-Rite 200S 2 Axis DRO & Collet Closer	321548
GH-1440W-1 with Acu-Rite 200S 2 Axis DRO, Taper Attachment & Collet Closer	321564
GH-1440W-1 with Newall DP700 2-Axis DRO	321134
GH-1440W-1 with Newall DP700 2-Axis DRO & Taper Attachment	321145
GH-1440W-1 with Newall DP700 2-Axis DRO & Collet Closer	321558

GH-1440W-3 LATHE AND ACCESSORY PACKAGES INSTALLED

GH-1440W-3 with Taper Attachment	321522
GH-1440W-3 with Collet Closer	321729
GH-1440W-3 with Acu-Rite VUE 2 Axis DRO	321404
GH-1440W-3 with Acu-Rite VUE 2 Axis DRO & Taper Attachment	321176
GH-1440W-3 with Acu-Rite VUE 2 Axis DRO & Collet Closer	321406
GH-1440W-3 with Acu-Rite 200S 2 Axis DRO	321533
GH-1440W-3 with Acu-Rite 200S 2 Axis DRO & Taper Attachment	321563
GH-1440W-3 with Acu-Rite 200S 2 Axis DRO & Collet Closer	321524
GH-1440W-3 with Acu-Rite 200S 2 Axis DRO, Taper Attachment & Collet Closer	321572
GH-1440W-3 with Newall DP700 2-Axis DRO	321135
GH-1440W-3 with Newall DP700 2-Axis DRO & Taper Attachment	321144
GH-1440W-3 with Newall DP700 2-Axis DRO & Collet Closer	320536



TAPER ATTACHMENT
321520

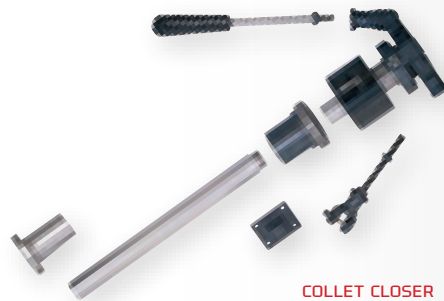

COLLET CLOSER
321519

13" x 40" GEARED HEAD BENCH LATHE

Yet another advancement in the field of Metal Turning led by JET. Designed for smooth, quiet operation and user versatility a JET Geared Head Bench Lathe cuts and tapers with exacting accuracy. JET Geared Head Bench Lathes feature extensive standard equipment packages that add to the ease of operation and production flexibility.

CONTACT CUSTOMER SERVICE AT 888-804-7129 FOR ADDITIONAL CUSTOMIZED PACKAGES



FEATURES

- Enclosed gearbox design provides smooth, quiet operation
- Hardened and ground gears are featured in the headstock and gearbox
- V-way bed is induction hardened and ground
- Gap bed section provided for large diameter work
- Adjustable gibs are incorporated in the carriage and slideways
- Fast, easy speed changes
- D1-4 spindle is precision ground for accuracy and supported by high quality tapered roller bearings
- Headstock is constantly oiled during operation
- Gear box gives wide inch threading and feed capabilities with no gear changes
- Independent leadscrew and feed rod
- Spindle actuation control is apron mounted
- Compound and cross slide have backlash adjustment
- Tailstock may be offset for turning tapers and includes an inch/metric graduated quill

STANDARD EQUIPMENT

- Coolant tray
- Tolerance test certificate
- 6" 3-jaw direct mount scroll chuck with top reversing jaws
- 8" 4-jaw independent chuck
- 12" faceplate
- Four-way tool post
- Steady and follow rest
- Metric change gear
- Centers with headstock center sleeve
- Threading dial
- Tool box with tools
- Splash guard
- Micro Carriage Bed Stop

STOCK NUMBER	321357A	321359A
Model Number	GHB-1340A	GHB-1440A
Swing over Bed (in.)	13	14
Swing over Cross Slide (in.)	7-25/32	9-1/16
Swing Through Gap (in.)	18-3/4	20
Length of Gap (in.)	8	8
Distance Between Centers (in.)	43	43
Spindle Bore (in.)	1-3/8	1-3/8
Spindle Mount	D1-4	D1-4
Spindle Taper (w/ Sleeve)	MT-5 (MT-3)	MT-5 (MT-3)
Number of Spindle Speeds	8	8
Range of Spindle Speeds (RPM)	70 - 2,000	70 - 2,000
Number of Longitudinal and Cross Feed Rates	40	40
Range of Longitudinal Feeds (IPR)	0.0018 - 0.0374	0.0018 - 0.0374
Range of Cross Feeds (IPR)	0.0006 - 0.0130	0.0006 - 0.0130
Number of Inch Threads	38	38
Range of Inch Threads (TPI)	3-1/2 - 80	3-1/2 - 80
Number of Metric Threads	23	23
Range of Metric Threads	0.45 - 10	0.45 - 10
Max Tool Size (in.)	5/8 x 5/8	5/8 x 5/8
Compound Slide Travel (in.)	2-11/16	2-11/16
Cross Slide Travel (in.)	6-5/16	6-5/16
Carriage Travel (in.)	35	35
Tailstock Spindle Travel (in.)	3-3/4	3-3/4
Taper in Tailstock Spindle	MT-3	MT-3
Steady Rest Capacity (in.)	2-3/4	2-3/4
Follow Rest Capacity (in.)	2-3/8	2-3/8
Width of Bed (in.)	7-3/8	7-3/8
Overall Dimensions (in./ L x W x H)	79 x 28-1/2 x 30	79 x 28-1/2 x 30
Motor	2HP, 1Ph, 230V	2HP, 1Ph, 230V
Net Weight (lbs.)	1,154	1,211



GHB-1340A LATHE AND ACCESSORY PACKAGES INSTALLED

GHB-1340A with Acu-Rite VUE 2 Axis DRO & Collet Closer	321102
GHB-1340A with Taper Attachment	321119
GHB-1340A with Acu-Rite VUE 2 Axis DRO	321103
GHB-1340A with Taper Attachment & Collet Closer	321129
GHB-1340A with Newall DP700 2-Axis DRO, Collet Closer & Taper Attachment	321104
GHB-1340A with Newall DP700 2-Axis DRO & Taper Attachment	321115
GHB-1340A with Acu-Rite 200S 2 Axis DRO	321122
GHB-1340A with Acu-Rite 200S 2 Axis DRO & Taper Attachment	321123
GHB-1340A with Collet Closer	321124
GHB-1340A with Acu-Rite 200S 2 Axis DRO & Collet Closer	321125
GHB-1340A with Acu-Rite 200S 2-Axis DRO, Taper Attachment & Collet Closer	321127
GHB-1340A with Newall DP700 2-Axis DRO	321131
GHB-1340A with Acu-Rite VUE 2 Axis DRO, Taper Attachment & Collet Closer	321226
GHB-1340A with Newall DP700 2-Axis DRO & Collet Closer	321581
GHB-1340A Lathe with CBS-1340A Stand	321101AK
GHB-1340A Lathe with ACU-RITE VUE DRO & Stand	321103AK

GHB-1440A LATHE AND ACCESSORY PACKAGES INSTALLED

GHB-1440A with Acu-Rite VUE 2 Axis DRO & Collet Closer	321107
GHB-1440A with Taper Attachment	321157
GHB-1440A with Acu-Rite VUE 2 Axis DRO	321158
GHB-1440A with Taper Attachment & Collet Closer	321159
GHB-1440A with Acu-Rite 200s 2-Axis DRO & Taper Attachment	321161
GHB-1440A Bench Lathe with Stand	321156K

CALL FOR ADDITIONAL PACKAGES



ENCLOSED GEARBOX



COMPLETE WITH 4-WAY TOOL POST AND 3-JAW CHUCK MOUNTED FOR EASE OF USE

13" x 40" BELT DRIVE BENCH LATHE

The industry standard in Metal Turning, JET Belt Drive Bench Lathes come fully loaded and designed to accommodate a huge variety of optional accessories to perform a variety of operations, while increasing overall production. A JET Belt Drive Bench Lathe allows the operator to change between standard and metric gears quickly and easily to enhance productivity and efficiency, and create finely-shaped tapering with great precision.



SHOWN WITH OPTIONAL STAND



**CONTACT CUSTOMER SERVICE AT
888-804-7129 FOR ADDITIONAL
CUSTOMIZED PACKAGES**

FEATURES

- Enclosed gearbox design provides smooth, quiet operation
- Fast, easy speed changes
- Helical cut headstock gears reduce noise
- V-way bed is induction hardened and ground
- Gap bed section provided for large diameter work
- Low voltage motor controls
- Changes gears allow metric threading
- Spindle is supported by precision tapered roller bearings
- Independent leadscrew and feed rod
- T-slotted compound slide with four-way tool post
- Carriage mounted spindle control lever
- Automatic feeding and threading are fully interlocked
- Tailstock may be offset for turning tapers and includes an inch/metric graduated quill

STANDARD EQUIPMENT

- Coolant tray
- 6" 3-jaw direct mount scroll chuck with top reversing jaws
- 8" 4-jaw independent chuck
- 12" faceplate
- Four-way tool post
- Steady and follow rest
- Metric change gear
- Centers with headstock center sleeve
- Threading dial
- Micro Carriage Bed Stop
- Full Length Splash Guard
- Tolerance test certificate
- Tool box with tools

BDB-1340A LATHE AND ACCESSORY PACKAGES INSTALLED

BDB-1340A with Acu-Rite VUE 2-Axis DRO & Collet Closer	321108
BDB-1340A with Acu-Rite VUE 2 Axis DRO	321110
BDB-1340A with Collet Closer	321111
BDB-1340A with Taper Attachment & Collet Closer	321112
BDB-1340A with Acu-Rite 200S 2 Axis DRO	321121
BDB-1340A with Newall DP700 2-Axis DRO	321130
BDB-1340A with CBS-1340A Stand	321102AK
BDB-1340A with Taper Attachment	321120

STOCK NUMBER	321360A
Model Number	BDB-1340A
Swing over Bed (in.)	13
Swing over Cross Slide (in.)	7-25/32
Swing Through Gap (in.)	18-3/4
Length of Gap (in.)	8
Distance Between Centers (in.)	40
Spindle Bore (in.)	1-3/8
Spindle Mount	D1-4
Spindle Taper (w/ Sleeve)	MT-5 (MT-3)
Number of Spindle Speeds	12
Range of Spindle Speeds (RPM)	60 - 1,240
Number of Longitudinal and Cross Feed Rates	40
Range of Longitudinal Feeds (IPR)	.0018 - .0374
Range of Cross Feeds (IPR)	.0012 - .0345
Number of Inch Threads	40
Range of Inch Threads (TPI)	4-112
Number of Metric Threads	27
Range of Metric Threads	0.2-6
Max Tool Size (in.)	5/8 x 5/8
Compound Slide Travel (in.)	2-11/16
Cross Slide Travel (in.)	6-5/16
Carriage Travel (in.)	35
Tailstock Spindle Travel (in.)	3-3/4
Taper in Tailstock Spindle	MT-3
Steady Rest Capacity (in.)	2-5/8
Follow Rest Capacity (in.)	2-3/4
Width of Bed (in.)	7-3/8
Overall Dimensions (in./ L x W x H)	71 x 32 x 45 with Stand
Motor	2HP, 1Ph, 230V
Net Weight (lbs.)	1,175

9" x 20" BELT DRIVE BENCH LATHE

JET's BD-920W now comes complete with splash guard along with our enclosed gearbox and fully stocked with 2 chucks and centers make it shop ready.



SHOWN WITH
OPTIONAL STAND

FEATURES

- Spindle supported by precision tapered roller bearings
- Hardened and ground bedways
- Reversing switch included for added versatility
- Backlash adjustments provided throughout the carriage
- Quick change gearbox provides wide range of inch and metric threads
- Power Longitudinal feed allows threading and reverse threading
- Standard 1-1/2 x 8 TPI spindle mount allows for many aftermarket accessories
- Tailstock is adjustable for taper cuts

STANDARD EQUIPMENT

- 4" 3-jaw chuck with threaded back plate
- 7" 4-jaw chuck with threaded back plate
- Metric Change gears
- Enclosed gear box
- Centers
- Threading dial
- Full length splash guard



*NEW FULL LENGTH SPLASH GUARD

STOCK NUMBER	321376
Model Number	BD-920W
Swing over Bed (in.)	9
Swing over Cross Slide (in.)	5-5/16
Distance Between Centers (in.)	20
Spindle Bore (in.)	7/8
Spindle Mount (TPI)	1/2 x 8
Spindle Taper w/ Sleeve	MT-3
Number of Spindle Speeds	6
Range of Spindle Speeds (RPM)	130 - 2,000
Number of Longitudinal Feed Rates	60
Range of Longitudinal Feeds (IPR)	.0006 - .037
Number of Inch Threads	30
Range of Inch Threads (TPI)	8 - 60
Number of Metric Threads	18
Range of Metric Threads	0.4 - 3.5
Max Tool Size (in.)	1/2 x 1/2
Compound Slide Travel (in.)	1-7/8
Cross Slide Travel (in.)	4-3/8
Carriage Travel (in.)	16
Tailstock Spindle Travel (in.)	1-9/16
Taper in Tailstock Spindle	MT-2
Steady Rest Capacity (in.)	1/4 - 1-7/8
Follow Rest Capacity (in.)	1/4 - 1-1/8
Width of Bed (in.)	4-1/2
Overall Dimensions (in./ L x W x H)	37 x 18-3/4 x 17-3/8
Motor	3/4HP, 1Ph, 115V Only
Net Weight (lbs.)	265

OPTIONAL EQUIPMENT	STOCK NUMBER
S-920N Stand for BD-920N	321374
Lathe with S-920N Stand	321155K

ACCESSORIES

Enhance shop operations and versatility with a wide range of quality accessories from JET.



QUICK CHANGE TOOL POST SETS- WEDGE TYPE

FEATURES

- #1 Boring & Facing
- #2 Boring, Turning & Facing
- #4 Boring, Heavy-duty
- #7 Universal Parting Blade
- #10 Knurling, Facing & Turning
- Working parts hardened and ground
- Maximum rigidity for chatter-free performance
- Holders fit Aloris and YUASA tool posts
- Increases productivity of all lathe operations
- Completely sealed for maintenance free operation
- Change tools in seconds
- Base must be machined to fit your lathe. For JET Lathes see chart below for specifications.

DIMENSIONS FOR MACHINING YOUR TOOL POST TO FIT YOUR JET LATHE. DISTANCE FOR TOOL POST SIZE ON ALL JET METAL LATHES.

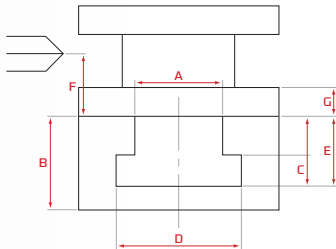

STOCK NUMBER	650295	650300	650305
Series	200 (BXA)	300 (CXA)	400 (CA)
Fits Swing Lathe Size (in.)	10 - 15	10 - 18	14 - 20
Net Weight (lbs.)	6	6	7



MODEL NO.	A	B	C	D	E	F	G
BDB1340A	1.26	1.378	0.315	2	0.63	1.417	0.787
GHB1340A	1.26	1.378	0.315	2	0.63	1.417	0.787
GH1340W	1.375	1.5	0.335	2	0.689	1.708	0.708
GH1440W	1.375	1.5	0.335	2	0.689	1.708	0.708
GH1440ZX, GH1460ZX	1.375	1.5	0.5	1.968	1.125	1.63	0.63
GH1640ZX, GH1660ZX	1.375	1.968	0.5	1.968	1.125	1.87	0.866
GH1840ZX, GH1860ZX, GH1880ZX	1.375	1.968	0.5	1.968	1.125	1.87	0.866
GH2280ZX	1.375	2.75	0.5	1.968	1.125	1.87	0.866

ALORIS SUPER-PRECISION INTRO-PRO SETS

Precision-engineered to ensure repetitive accuracy. Advanced design provides built-in quick tool changing, versatility with positive rigidity to meet the most exacting working tolerances. Quickly and easily installed on any engine lathe, bench or CNC lathe for a wide range of operations - from fine precision work to heavy-duty cutting.

The deluxe, affordable beginner's set built by the world's #1 quick change tool post manufacturer.

STOCK NUMBER	650295
650270	BXA Aloris Intro Set for 14" ZX Lathes
650275	CXA Aloris Intro Set for 16" ZX Lathes
650280	CA Aloris Intro Set for 18" ZX Lathes
650285	CA Aloris Intro Set for 22" ZX Lathes
650290	DA Aloris Intro Set for 26" ZH Lathes

INTRO-PRO SET

(Includes one each):

- Super Precision Tool Post
- #1 Tool Holder
- #2 Tool Holder

TURNING AND FACING HOLDER:

Takes various sizes of bits. Turning and facing tools can be locked in together. Saves time and labor when changing operations.

BORING, TURNING AND FACING HOLDER:

"V" groove holds round shank boring bars and tools as well as square tool bits.



TOOLING KITS FOR JET LATHES

660200 KIT INCLUDES:

- Three double ended boring bars
- Parting tool holder
- Adjustable turning tool holder
- Revolving knurling tool with three pairs of knurls
- Half dead center
- Carbide tipped dead center
- Heavy-duty live center
- Cut off tool
- Eight HSS tool bits
- Four hex key wrenches
- Works with 13" and 14" W Series and Bench Series Lathes



660200

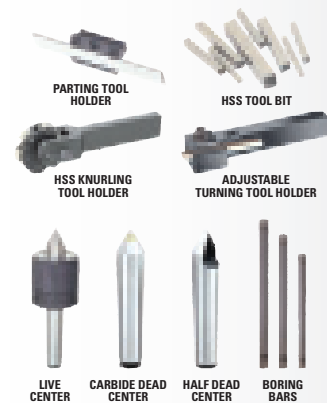

660210 KIT INCLUDES:

- Three double ended boring bars
- Parting tool holder
- Adjustable turning tool holder
- Revolving knurling tool with three pairs of knurls
- Half dead center
- Carbide tipped dead center
- Heavy-duty live center
- Cut off tool
- Eight HSS tool bits
- Four hex key wrenches
- Works with all ZX Series Lathes



660210



NEW

660215 KIT INCLUDES:

- Quick Change Tool Post with 4 holders
- MT2 Live Centers
- 2pc Indexable Turning Tool Right & Left Hand
- Boring Tool
- HSS Internal Threading Tool
- Parting Tool holder w/HSS Blade
- HSS Parting Blade
- Works with the BD-920W lathe



660215



STOCK NUMBER	DESCRIPTION
660200	22-piece Turning Tool Kit for 13" & 14" W Series & Bench Series Lathes
660210	23-piece Turning Tool Kit for all ZX Series Lathes
660215	Tooling kit for BD-920W

ACCESSORIES

JET offers a complete line of accessories for all its machines.



5-C COLLET SETS & RACKS

FEATURES

- Precision hardened and ground
- C Collets for use on lathes
- Premium collets with 0.0005mm T.I.R.

STOCK NO.	DESCRIPTION
650014	CS-5C 16 pcs 5-C collet set 1/8" to 1 1/16" by 1/16th
650015	18 pc Premium 5C collet set 1/16" to 1-1/8" by 16th with Metal Rack
650016	35 pc Premium 5C collet set 1/16" to 1-1/8" by 32nds with Metal Rack
650017	Metal collet rack holds 30 5C collets
650018	Metal collet rack holds 72 5C collets



650014

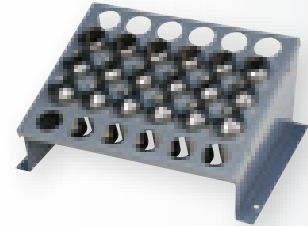

650015



650016

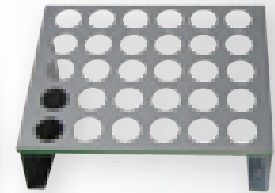

650017

COOLANT SYSTEM

FEATURES

- For use with BDB-1340, GHB-1340 & GHB 1440
- 1/8 HP, 115V 3 gallon per minute flow rate
- Requires drilling of chip pan

STOCK NUMBER	DESCRIPTION
321444	CP-13BD, Coolant Pump Kit for 321357A and 321360A



TAPER ATTACHMENTS

FEATURES

- Specially designed for each model
- 10° inclusive cutting capacity
- Mounts to predrilled and tapped holes
- Factory installation available

STOCK NUMBER	MODEL NUMBER	MAX. TAPER LENGTH (IN.) AT 10° ANGLE
321442	BDB-1340A	10
321442	GHB-1340A	10
321520	All W models	10-5/8
321291	All ZX models	18

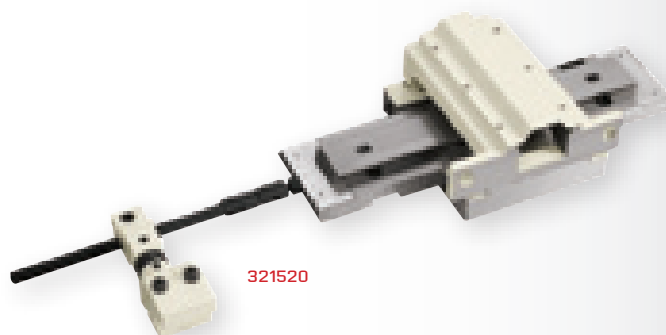

321520

COLLET CLOSER

FEATURES

- Specially designed for each model
- Precision ground components
- Uses 5C collets
- Rear mounted lever action
- Some drilling and other modification may be required

STOCK NUMBER	MODEL NUMBER
321515A	BDB-1340A
321514A	GHB-1340A
321519	All W models
321292	All ZX models



321515A

ACU-RITE AND NEWALL DRO SERIES FOR TURNING APPLICATIONS

The days of inaccurate measurement conversions due to math errors and productivity lulls caused by lost data are over. JET offers a variety of Digital Readout packages for JET Turning Machines designed to keep track of position, provide prompt feedback and messaging, and quick configuration of machine features. Die-cast metal construction ensures unit reliability and displays are very easy to read. Add the right Digital Readout unit to the JET Lathe in your shop.

VUE ACU-RITE DIGITAL READOUT

The Acu-Rite VUE is a cost-effective, entry-level solution for manual machine tool applications. With our innovative LCD display screen technology and versatile software to accommodate milling, turning or grinding applications the VUE is everything you need at a price you can afford.



COMMON FEATURES

- 1, 2 or 3 axis 5.7" Transmissive LCD display
- Help Function
- 16 Tool Offsets/Diameter
- Preset and zero reset

- 4 Function Calculator/Trig Calculator
- Instant Inch/mm conversion
- 200mm Fixed Reference Marks

TURNING SPECIFIC FEATURES

- Lock axis feature—used in conjunction with tool offsetting, lets you establish tool offsets with the tool under load, resulting in reduced tool deflection.
- Instant radius/diameter conversion

200S ACU-RITE DIGITAL READOUT

As the industry standard in digital readout systems, the Acu-Rite 200S offers state-of-the-art features for milling, turning and grinding applications.

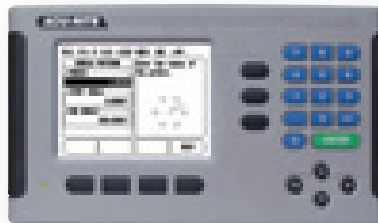

COMMON FEATURES

- 2 or 3 axis 5.7" Transmissive LCD display
- Help Function
- 16 Tool Offsets/Diameter
- Preset and zero reset

- 4 Function Calculator/Trig Calculator
- Instant Inch/mm conversion
- Position-Trac™ Home Reference

TURNING SPECIFIC FEATURES

- Lock axis feature
- Instant radius/diameter conversion
- Taper Calculator
- CSS (option)

300S ACU-RITE DIGITAL READOUT

The Acu-Rite 300S is a fully programmable 4 axis readout system, now available with a full color display. With the capability to store and create a library of programs the 300S is everything you need to create, edit and execute programs on your manual machine tool.

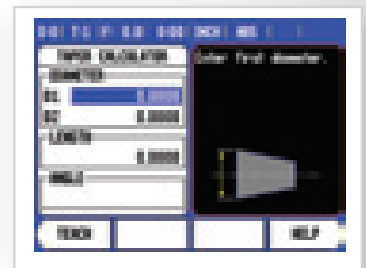
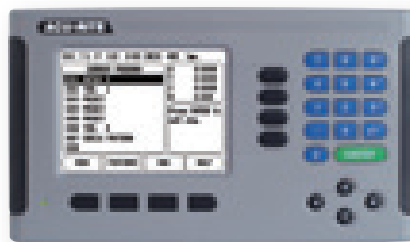

COMMON FEATURES

- 2, 3 or 4 axis 5.7" Full Color Display
- Multiple program names with numerous steps
- Multiple display views
- Job Clock
- Feed Rate Display
- Multiple Language Support
- Absolute/Incremental
- Near-Zero Warning
- Help Function
- 16 Tool Offsets/Diameter
- Preset and zero reset
- 4 Function Calculator/Trig Calculator
- Instant Inch/mm conversion
- Position-Trac™ Home Reference

TURNING SPECIFIC FEATURES

- Lock axis feature
- Instant radius/diameter conversion
- Taper Calculator

DP700 NEWALL DIGITAL READOUT

The DP700 is the latest in Newall's line of a powerful and intuitive DROs. The unit is housed in a rugged, ergonomically designed casting. The DRO features all of the essential functions for milling, boring, turning, grinding, and general machining operations.



NEWALL



COMMON FEATURES

- Clean, Crisp, Easy to Read, LEDs
- Intuitive Message Window
- Long Life Membrane Keypad
- Solid cast construction
- Safe, Low Voltage Power Supply (UL)
- Panel Mount Version Available
- Feed Rate Display
- Bolt Hole Circle Routine
- Line Hole Routine
- Arc Contouring
- Programmable Memory/Teach
- Polar Coordinates
- Line Hole Calculator
- Tool Offsets
- Taper Calculations
- Axis Vectoring/Summing
- Undo
- Linear and Segmented Error Comp.
- RS232 Output
- Languages: English, French, German, Spanish, Italian, Turkish, Czech, Russian, Portuguese, Danish

The DP700 is compatible with Newall's Spherosyn and Microsyn encoders which withstand the harshest shop conditions.

TURNING HELPFUL INFO

IN ADDITION TO MANUFACTURING PRECISION MACHINES,
JET STRIVES TO MAKE YOUR JOB EASIER WITH SOME
BASIC INFORMATION ABOUT ALL OUR TURNING PRODUCTS.



ENGINE LATHES

The size of an engine lathe is determined by the largest piece of stock that can be machined. Before machining a workpiece, the following measurements must be considered: the diameter of the work that will swing over the bed and the length between lathe centers.

Engine lathes all have the same general functional parts; the bed is the foundation of the working parts of the lathe. The main feature of its construction is the ways which are formed on its upper surface and run the full length of the bed. Ways provide the means for holding the tailstock and carriage, which slide along the ways, in alignment with the permanently attached headstock.

The headstock is located on the operator's left end of the lathe bed. It contains the main spindle and oil reservoir and the gearing mechanism for obtaining various spindle speeds and for transmitting power to the feeding and threading mechanism. The headstock is driven by an electric motor connected either to a belt, pulley or geared system. The spindle has a hole through its entire length to accommodate long workpieces.

The tailstock is located on the opposite end of the lathe from the headstock. It supports one end of the workpiece when machining between centers, supports long pieces held in the chuck, and holds various forms of cutting tools such as drills, reamers and taps.

The carriage includes the apron, saddle, compound rest, cross slide, tool post and the cutting tool. It sits across the ways and in front of the bed. The function of the carriage is to carry and move the cutting tool. It can be moved by hand or power and can be clamped into position with a locking nut. The saddle carries the cross slide and the compound rest. The cross slide is mounted on the ways on top of the saddle and is moved back and forth at 90 degrees to the axis of the lathe by the cross slide lead screw.

COMMON TERMINOLOGY OF A MANUAL LATHE

- A** GAP: THE GAP ALLOWS YOU TO TURN A LARGER DIAMETER WORK PIECE.
- B** SWING (EX: 14")
- C** DISTANCE BETWEEN CENTERS IS FROM CHUCK TO TAILSTOCK
- D** LENGTH OF BED

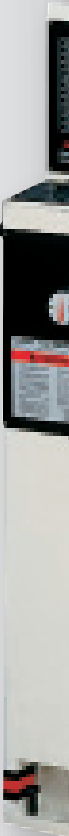





MILLING

JET Milling machines and components are manufactured to deliver precision cuts job after job. Industry professionals know JET Step Pulley, Variable Speed and CNC Mills provide the reliability and flexibility to keep even the busiest shops up and running, with superior results on every part turned out. Clearly-written, professional manuals get you started with ease, and every JET Mill is backed by our industry-leading Two Year Warranty.



PRECISE, EFFICIENT
& ACCURATE. TO
FIT YOUR SHOP'S
NEEDS.

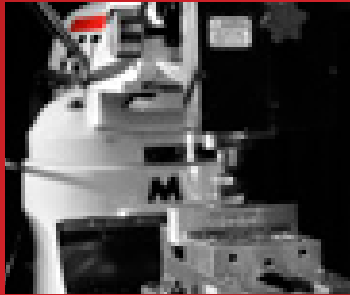

CONTENTS

CNC VERTICAL MILL.	64-66
VARIABLE SPEED VERTICAL MILLS	68-75
STEP PULLEY MILLS.	76-79
MILL/DRILL.	80-81
ACCESSORIES	82-85
DIGITAL READOUTS	86-87
MILLING HELPFUL INFO.	88-89

CNC VERTICAL MILLING MACHINE PACKAGES

JET offers complete, factory-installed CNC packages with your choice of 2 or 3-axis CNC controls. The Computer Numerical Control system brings the added precision of digital automation to the process, allowing the user greater control and efficiency. Meehanite® casted JET Vertical Mills with CNC packages deliver accurate results every time.



FEATURES OF THE ACU-RITE MILLPWR® 2- OR 3-AXIS CONTROL

- Increased Productivity, mill more efficiently and effectively
- Bolthole Calculations, calculate bolthole patterns instantly
- Tool Offsets and Tool Library
- Jog Control, move quickly from one location to another—using one axis at a time or any two axes simultaneously
- 3-D Contouring, ability to import and run G-code files from CAD/CAM programs
- Mirror/Repeat/Rotate, easily manipulate part programs to save time and reduce program steps.
- Ease of use, convenient, user-friendly and multi-faceted
- 10" flat panel, vivid, color, LCD display to view immediate graphic feedback
- Menu-prompted Conversational programming, easily create part programs, edit, reverse, change, delete and copy/move steps—follow the menu prompts and let MILLPWR® do the rest
- Info Button, built-in help screens for content specific jobs
- Built-in Calculator, perform standard, trig and geometry calculations and transfer them directly into part programs

FEATURES OF THE JTM-1050

- Meehanite casting
- Precision bored and honed milling head
- Large diameter quill is chromed
- High precision Class 7 spindle bearings
- Spindle head is internally cooled
- Satin chrome finished dials
- Heavy-duty motor drive
- One-piece quill pinion shaft
- Three-stage power downfeed with automatic stop
- Heavy-duty spindle brake
- Chrome plated motor shaft with lower bearing support at end
- Adjustable gibs throughout
- Internal coolant tank built into base for use with coolant system (Coolant pump not included)
- Tolerance test sheet included
- Locks on all movable surfaces
- Hardened and ground table

FEATURES OF THE JTM-4VS

- Meehanite® casting
- Heavy-duty splined motor drive
- Three-stage power downfeed with automatic stop
- Adjustable gibs throughout
- Precision bored and honed milling head
- Large diameter quill is chromed
- High precision Class 7 spindle bearings
- Spindle head is internally cooled
- Satin chrome finished dials
- One-piece quill pinion shaft
- Heavy-duty spindle brake
- Chrome plated motor shaft with lower bearing support
- Internal coolant tank built into base for use with coolant system (Coolant pump not included)
- Tolerance test sheet included

STANDARD EQUIPMENT

- Locks on all movable surfaces
- Precision hardened and ground ways and table
- One-shot lubrication system
- Way covers
- Draw bar
- Tool box with tools



JET CNC PACKAGES ALSO AVAILABLE WITH THE NEW ACU-RITE 3500I CONTROL!



STOCK NUMBER	690908 & 690918	690900 & 690910
Model Number	JTM-4VSCNC	JTM-1050CNC
2-Axis CNC	690908	690900
3-Axis CNC	690918	690910
CNC Package	ACU-RITE MILLPWR®	ACU-RITE MILLPWR®
Table Size (in.)	9 x 49	10 x 50
Spindle Taper	R-8	R-8
Quill Diameter (in.)	3-3/8	3-3/8
Number of Spindle Speeds	Variable	Variable
Range of Spindle Speeds (RPM)	60 - 4,200	70 - 3,800
Quill Down Feed Rates (IPR)	.0015 - .003 - .006	.0015 - .003 - .006
Spindle Travel (in.)	5	5
Head Movement (deg.)	90° R & L, 45° F & B	90° R & L, 45° F & B
Max Distance Spindle to Table (in.)	17-1/2	19
Distance Spindle to Column (max./in.)	19	26
Distance Spindle to Column (min./in.)	4-1/2	5-1/2
Collet Capacity	1/8 - 7/8	1/8 - 7/8
Table Longitudinal Travel (in.)	34	30
Table Cross Travel (in.)	12	15-1/4
T-Slots Number and Size (in.)	3 and 5/8	3 and 5/8
T-Slot Centers (in.)	2-1/2	2-1/2
Work Table Weight Capacity (lbs.)	660	720
Travel of Knee (in.)	14-1/2	14-1/4
Travel of Ram (in.)	13-3/8	20-1/2
Motor	3HP, 230/460V, 3Ph, Prewired 230V	3HP, 230/460V, 3Ph, Prewired 230V
Overall Dimensions (in./ L x W x H)	66 x 63 x 85	96 x 69 x 87
Net Weight (lbs.)	2,420	3,200

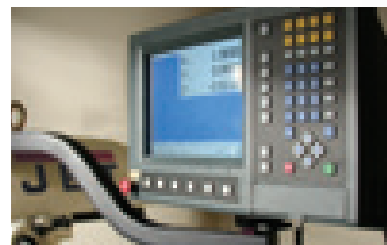

10" FLAT PANEL, COLOR LCD DISPLAY TO VIEW IMMEDIATE GRAPHIC FEEDBACK



PRECISION GLASS SCALES FOR IMPROVED ACCURACY AND CONSISTENCY, ELIMINATION OF BACKLASH AND MUCH MORE!

CNC VERTICAL MILLING MACHINE PACKAGES



ADDITIONAL PACKAGES ARE AVAILABLE WITH THE ACU-RITE 3500I CONTROL. CONTACT CUSTOMER SERVICE AT 888-804-7129 FOR INFORMATION.



FEATURES OF THE JTM-1050EVS

- Meehanite casting
- Runs quieter and smoother than conventional variable speed head
- Large diameter quill is chromed
- High precision Class 7 spindle bearings
- Low maintenance head has less moving parts
- No belt slippage allows more power at the spindle
- Heavy-duty motor drive
- One-piece quill pinion shaft
- Heavy-duty spindle brake
- Adjustable gibs throughout

FEATURES OF THE JTM-1054R & JTM-1055

- Meehanite casting
- Hardened and ground table certified to be 52C Rockwell hardness
- Chrome leadscrews on X and Y axis
- Box style ways on Y and Z axis
- Satin chrome finished dials
- Precision bored and honed milling head
- Large diameter quill is chromed
- High precision Class 7 spindle bearings
- Chrome plated motor shaft has lower bearing support
- Motor pulleys are ground to increase belt lift
- One-piece quill pinion shaft

STANDARD EQUIPMENT

- Locks on all movable surfaces
- Precision hardened and ground ways and table
- One-shot lubrication system
- Way covers
- Draw bar
- Tool box with tools

STOCK NUMBER	690902 & 690912	690904 & 690914	691924 & 691923	691925 & 691926
Model Number	JTM-1050EVS/230CNC	JTM-1050EVS/460CNC	JTM-1054R	JTM-1055
2-Axis CNC	690902	690904	691924	691925
3-Axis CNC	690912	690914	691923	691926
CNC Package	ACU-RITE MILLPWR®	ACU-RITE MILLPWR®	ACU-RITE MILLPWR®	ACU-RITE MILLPWR®
Table Size (in.)	10 x 50	10 x 50	10 x 54	10 x 54
Spindle Taper	R-8	R-8	R-8	NST #40
Quill Diameter (in.)	3-3/8	3-3/8	3-3/8	4-1/8
Number of Spindle Speeds	Variable	Variable	Variable	Variable
Range of Spindle Speeds (RPM)	10 - 3,600	10 - 3,600	80 - 3,800	80 - 3,800
Quill Down Feed Rates (IPR)	.0015 - .003 - .006	.0015 - .003 - .006	.0015 - .003 - .006	.0015 - .003 - .006
Spindle Travel (in.)	5	5	5	5
Head Movement (deg.)	90° R & L, 45° F & B	90° R & L, 45° F & B	90° R & L, 45° F & B	90° R & L
Max Distance Spindle to Table (in.)	19	19	20	20
Distance Spindle to Column (max./in.)	26	26	26	26
Distance Spindle to Column (min./in.)	5-1/2	5-1/2	5-1/2	5-1/2
Collet Capacity	1/8 - 7/8	1/8 - 7/8	1/8 - 7/8	1/8 - 7/8
Table Longitudinal Travel (in.)	30	30	32	32
Table Cross Travel (in.)	15-1/4	15-1/4	16	16
T-Slots Number and Size (in.)	3 and 5/8	3 and 5/8	3 and 5/8	3 and 5/8
T-Slot Centers (in.)	2-1/2	2-1/2	2-1/2	2-1/2
Work Table Weight Capacity (lbs.)	720	720	800	800
Travel of Knee (in.)	14-1/4	14-1/4	17-1/2	17-1/2
Travel of Ram (in.)	20-1/2	20-1/2	20-1/2	20-1/2
Motor	3HP, 230V Only, 3Ph	3HP, 460V Only, 3Ph	5HP, 230/460V, 3Ph, Prewired 230V	5HP, 230/460V, 3Ph, Prewired 230V
Overall Dimensions (in./ L x W x H)	96 x 71 x 88	96 x 71 x 88	108 x 80 x 80	108 x 80 x 92
Net Weight (lbs.)	3,000	3,000	3,300	3,000

MEEHANITE® OVERVIEW

FOR DECADES WE'VE BUILT JET MILLING MACHINES TO DEMANDING SPECIFICATIONS IN OUR SAME FACTORIES IN ORDER TO DELIVER CONSISTENT, WORLD CLASS QUALITY.

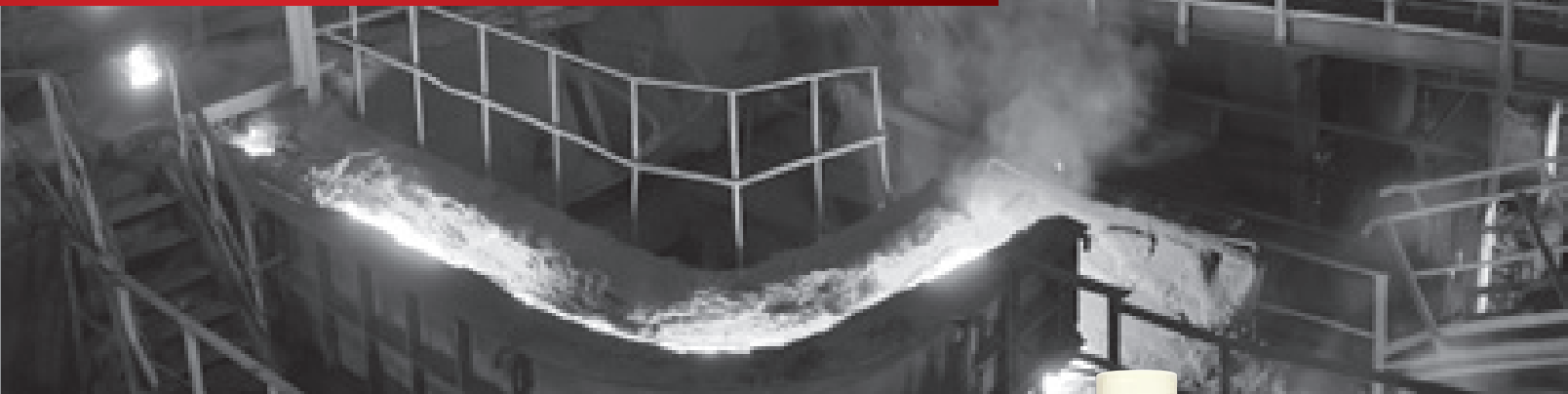

Meehanite® is a trademark for an engineering process to make many types of cast iron.

The production of Meehanite® metal requires know-how. At first, molten melt must have suitable mechanical properties required by the casting.

Not only is the chemical composition

important but also the control of super-cooling treatment to varying degree as determined by the amount of graphite ensures the strength and toughness of the finished material.

The Meehanite® process is not limited to controlling only the melt and material properties but rather is a total and integrated approach with systematic methodologies to all aspects of the casting production starting with the techniques of the casting process.

And the ultimate benefit to you is that your mill will retain its tolerances and the column will remain rigid through many years of machining!



JTM-1054R / JTM-1055

VARIABLE SPEED VERTICAL MILLING MACHINES

Combined durability and strength of Meehanite casting with the precision engineering of JET results in Variable Speed Vertical Milling Machines that turn out high quality components cut after cut. These heavy-duty mills are offered in both R-8 & NT-40 Spindles. All the features you've come to expect backed by the industry-leading JET Two Year Warranty.



FEATURES

- Meehanite® casting
- Box style ways on Y and Z axis
- High precision Class 7 spindle bearings
- Motor pulleys are ground to increase belt lift
- Hardened and ground table certified to be 52C Rockwell hardness
- Chrome leadscrews on X and Y axis
- Satin chrome finished dials
- Precision bored and honed milling head
- Large diameter quill is chromed
- Chrome plated motor shaft has lower bearing support
- One-piece quill pinion shaft

STANDARD EQUIPMENT

- One-shot lubrication system
- Way covers
- Draw bar
- Tool box with tools



HARDENED & GROUND 10X54" TABLE
CERTIFIED TO 52C ROCKWELL HARDNESS

STOCK NUMBER	690053	690055
Model Number	JTM-1054R	JTM-1055
Table Size (in.)	10 x 54	10 x 54
Spindle Taper	R-8	NST #40
Quill Diameter (in.)	3-3/8	4-1/8
Number of Spindle Speeds	Variable	Variable
Range of Spindle Speeds (RPM)	80 - 3,800	80 - 3,800
Quill Down Feed Rates (IPR)	.0015 - .003 - .006	.0015 - .003 - .006
Spindle Travel (in.)	5	5
Head Movement (deg.)	90° R & L, 45° F & B	90° R & L
Max Distance Spindle to Table (in.)	20	20
Distance Spindle to Column (max./in.)	26	26
Distance Spindle to Column (min./in.)	5-1/2	5-1/2
Collet Capacity	1/8 - 7/8	1/8 - 7/8
Table Longitudinal Travel (in.)	32	32
Table Cross Travel (in.)	15-3/4	15-3/4
T-Slots Number and Size (in.)	3 and 5/8	3 and 5/8
T-Slot Centers (in.)	2-1/2	2-1/2
Work Table Weight Capacity (lbs.)	800	800
Travel of Knee (in.)	17-1/2	17-1/2
Travel of Ram (in.)	20-1/2	20-1/2
Motor	5HP, 230/460V, 3Ph, Prewired 230V	5HP, 230/460V, 3Ph, Prewired 230V
Overall Dimensions (in./ L x W x H)	108 x 80 x 80	108 x 80 x 92
Net Weight (lbs.)	3,630	3,630



ACU-RITE 300S - DRO



NEWALL DP700 - DRO



690055

JTM-1055 MILL AND ACCESSORY PACKAGES INSTALLED	
JTM-1055 with X Axis Powerfeed & Air Draw Bar	690255
JTM-1055 with X & Y Axis Powerfeeds	690218
JTM-1055 with X & Y Axis Powerfeeds & Air Draw Bar	690260
JTM-1055 with Acu-Rite VUE 2-Axis DRO & X-Axis Powerfeed	690275
JTM-1055 with Acu-Rite 200S 2-Axis DRO	690250
JTM-1055 with Acu-Rite 200S 2-Axis DRO & X-Axis Powerfeed	690220
JTM-1055 with Acu-Rite 200S 2-Axis DRO & X & Y Axis Powerfeed	690222
JTM-1055 with Acu-Rite 200S 2-Axis DRO & X & Y & Z-Axis Powerfeed	690229
JTM-1055 with Acu-Rite 300S 2-Axis DRO & X-Axis Powerfeed	690320
JTM-1055 with Acu-Rite 300S 2-Axis DRO & X & Y Axis Powerfeed	690321
JTM-1055 with Newall DP700 2-Axis DRO	691222
JTM-1055 with Newall DP700 2-Axis DRO & X-Axis Powerfeed	691223
JTM-1055 with Newall DP700 2-Axis DRO & X & Y & Z-Axis Powerfeeds	691233
JTM-1055 with Newall DP700 2-Axis DRO & X & Y-Axis Powerfeeds	691224
JTM-1055 with Newall DP700 3-Axis DRO (Quill)	691225
JTM-1055 with Newall DP700 3-Axis DRO & X-Axis Powerfeed (Quill)	691226
JTM-1055 with Newall DP700 3-Axis DRO & X & Y-Axis Powerfeeds (Quill)	691227
JTM-1055 with Newall DP700 3-Axis DRO & X-Axis Powerfeed (Knee)	691238

JTM-1054R MILL AND ACCESSORY PACKAGES INSTALLED	
JTM-1054R with X Axis Powerfeed & Air Draw Bar	690274
JTM-1054R with Acu-Rite VUE 2-Axis DRO & X-Axis Powerfeed	690270
JTM-1054R with Acu-Rite VUE 2-Axis DRO & X-Axis Powerfeed & Air Draw Bar	690052
JTM-1054R with Acu-Rite VUE 2-Axis DRO & X & Y-Axis Powerfeeds	690272
JTM-1054R with Acu-Rite 200S 2-Axis DRO & X-Axis Powerfeed	690271
JTM-1054R with Acu-Rite 200S 2-Axis DRO & X & Y & Z-Axis Powerfeed	691292
JTM-1054R with Acu-Rite 300S 2-Axis DRO & X-Axis Powerfeed	690322

JTM-1050EVS ELECTRONIC VARIABLE SPEED VERTICAL MILLING MACHINE

The rugged stability of Meehanite casting enhances the overall precision of the JET JTM-1050EVS. Chrome lead screws on X & Y axis, no-slippage belt and heavy-duty motor drive enhance the user experience and operational efficiency. This is the Electronic Variable Speed Vertical Milling Machine for your shop.



FEATURES

- Runs quieter and smoother than conventional variable speed head
- Low maintenance head has less moving parts
- Meehanite® casting
- Turcite B on X axis and Y axis
- No fuse breaker power connection
- Chrome plated motor shaft with bearing support at end
- No belt slippage allows more power at the spindle
- Hardened and ground table
- Chrome lead screws on X and Y axis
- Large diameter quill is chromed
- High precision Class 7 spindle bearings
- Heavy-duty motor drive
- One-piece quill pinion and shaft

STANDARD EQUIPMENT

- One-shot lubrication system
- Chip Pan
- Way Covers
- Draw bar
- Tool box and tools

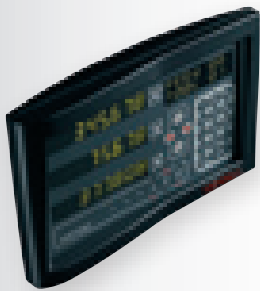

NEWALL DP700 - DRO



ACU-RITE 200S - DRO

STOCK NUMBER	690060	690062
Model Number	JTM-1050EVS/230	JTM-1050EVS/460
Table Size (in.)	10 x 50	10 x 50
Spindle Taper	R-8	R-8
Quill Diameter (in.)	3-3/8	3-3/8
Number of Spindle Speeds	Variable	Variable
Range of Spindle Speeds (RPM)	10 - 3,600	10 - 3,600
Quill Down Feed Rates (IPR)	.0015 - .003 - .006	.0015 - .003 - .006
Spindle Travel (in.)	5	5
Head Movement (deg.)	90° R & L, 45° F & B	90° R & L, 45° F & B
Max Distance Spindle to Table (in.)	19	19
Distance Spindle to Column (max./in.)	26	26
Distance Spindle to Column (min./in.)	5-1/2	5-1/2
Collet Capacity	1/8 - 7/8	1/8 - 7/8
Table Longitudinal Travel (in.)	30	30
Table Cross Travel (in.)	15-1/4	15-1/4
T-Slots Number and Size (in.)	3 and 5/8	3 and 5/8
T-Slot Centers (in.)	2-1/2	2-1/2
Work Table Weight Capacity (lbs.)	720	720
Travel of Knee (in.)	14-1/4	14-1/4
Travel of Ram (in.)	20-1/2	20-1/2
Motor	3HP, 230V Only, 3Ph	3HP, 460V Only, 3Ph
Overall Dimensions (in./ L x W x H)	96 x 71 x 88	96 x 71 x 88
Net Weight (lbs.)	3,000	3,000



690060

JTM-1050EVS MILL AND ACCESSORY PACKAGES INSTALLED

JTM-1050EVS/230 with X Axis Powerfeed	690011
JTM-1050EVS/230 with Acu-Rite 200S 3-Axis DRO (Knee)	690056
JTM-1050EVS/230 with Acu-Rite 200S 3-Axis DRO & X & Y-Axis Powerfeed & Air Draw Bar (Knee)	690124
JTM-1050EVS/230 with Acu-Rite 200S 2-Axis DRO & X-Axis Powerfeed	690127
JTM-1050EVS/230 with Acu-Rite 200S 3-Axis DRO & X & Y-Axis Powerfeed (Knee)	690155
JTM-1050EVS/230 with Acu-Rite 200S 2-Axis DRO & X-Axis Powerfeed & Air Draw Bar	690257
JTM-1050EVS/230 with Acu-Rite 300S 2-Axis DRO & X-Axis Powerfeed & Air Draw Bar	690300
JTM-1050EVS/230 with Acu-Rite 300S 3-Axis DRO & X & Y-Axis Powerfeed (Knee)	690310
JTM-1050EVS/230 with Acu-Rite 300S 2-Axis DRO & X-Axis Powerfeed	690311
JTM-1050EVS/230 with Acu-Rite 300S 2-Axis DRO & X & Y Axis Powerfeed	690312
JTM-1050EVS/230 with Acu-Rite VUE 2-Axis DRO & X-Axis Powerfeed	690404
JTM-1050EVS/230 with Acu-Rite 200S 2-Axis DRO & X & Y Axis Powerfeed	690406
JTM-1050EVS/230 with Acu-Rite VUE 2-Axis DRO & X & Z-Axis Powerfeeds	690414
JTM-1050EVS/230 with Acu-Rite 300S DRO, X, Y & Z-Axis Powerfeeds & Air Draw Bar	690273
JTM-1050EVS/230 with Newall DP700 3-Axis DRO, X & Z-Axis Powerfeeds (Quill)	690326
JTM-1050EVS/230 with Newall DP700 3-Axis DRO, X & Z-Axis Powerfeeds (Knee)	690223
JTM-1050EVS/230 with Newall DP700 2-Axis DRO	691210
JTM-1050EVS/230 with Newall DP700 2-Axis DRO & X-Axis Powerfeed	691211
JTM-1050EVS/230 with Newall DP700 2-Axis DRO & X & Y-Axis Powerfeeds	690129
JTM-1050EVS/230 with Newall DP700 3-Axis DRO (Quill)	691213
JTM-1050EVS/230 with Newall DP700 3-Axis DRO & X-Axis Powerfeed (Quill)	691214
JTM-1050EVS/230 with Newall DP700 3-Axis DRO & X & Y-Axis Powerfeeds (Quill)	691215

JTM-1050EVS/460 MILL AND ACCESSORY PACKAGES INSTALLED

JTM-1050EVS/460 with X Axis Powerfeed	690189
JTM-1050EVS/460 with Acu-Rite VUE 2-Axis DRO & X-Axis Powerfeed	690405
JTM-1050EVS/460 with Acu-Rite 200S 2-Axis DRO & X-Axis Powerfeed	690137
JTM-1050EVS/460 with Acu-Rite 200S 2-Axis DRO & X & Y Axis Powerfeed	690154
JTM-1050EVS/460 with Acu-Rite 200S 3-Axis DRO & X-Axis Powerfeed (Knee)	690138
JTM-1050EVS/460 with Acu-Rite 300S 2-Axis DRO & X-Axis Powerfeed	690316
JTM-1050EVS/460 with Acu-Rite 300S 2-Axis DRO & X & Y Axis Powerfeed	690313
JTM-1050EVS/460 with Newall DP700 2-Axis DRO	691216
JTM-1050EVS/460 with Newall DP700 2-Axis DRO & X-Axis Powerfeed	691217
JTM-1050EVS/460 with Newall DP700 2-Axis DRO & X & Y-Axis Powerfeeds	691218
JTM-1050EVS/460 with Newall DP700 2-Axis DRO & X & Y-Axis Powerfeeds & Air Draw Bar	691231
JTM-1050EVS/460 with Newall DP700 3-Axis DRO (Quill)	691219
JTM-1050EVS/460 with Newall DP700 3-Axis DRO & X-Axis Powerfeed (Quill)	691220
JTM-1050EVS/460 with Newall DP700 3-Axis DRO & X & Y-Axis Powerfeeds (Quill)	691221

JTM-1050 VARIABLE SPEED VERTICAL MILLING MACHINE

Like all JET Milling Machines, the JTM-1050 features Meehanite casting, large heavy-duty 10x50 table and precision engineering. Shop professionals who demand only the best know this JET Variable Speed Vertical Milling Machine is up to any task.



FEATURES

- Meehanite® casting
- Chrome lead screws on X and Y axis
- Turcite B on X and Y axis
- Precision bored and honed milling head
- High precision Class 7 spindle bearings
- No Fuse breaker power connection
- Hardened and ground table
- Satin chrome finished dials
- Large diameter quill is chromed
- Spindle head is internally cooled
- Heavy-duty motor drive
- Chrome plated motor shaft with bearing support at end
- One-piece quill pinion and shaft

STANDARD EQUIPMENT

- One-shot lubrication system
- Way covers
- Draw bar
- Tool box with tools



LARGE 10X50 HARDENED AND GROUND TABLE

STOCK NUMBER	690050
Model Number	JTM-1050
Table Size (in.)	10 x 50
Spindle Taper	R-8
Quill Diameter (in.)	3-3/8
Number of Spindle Speeds	Variable
Range of Spindle Speeds (RPM)	70 - 3,800
Quill Down Feed Rates (IPR)	.0015 - .003 - .006
Spindle Travel (in.)	5
Head Movement (deg.)	90° R & L, 45° F & B
Max Distance Spindle to Table (in.)	19
Distance Spindle to Column (max./in.)	26
Distance Spindle to Column (min./in.)	5-1/2
Collet Capacity	1/8 - 7/8
Table Longitudinal Travel (in.)	30
Table Cross Travel (in.)	15-1/4
T-Slots Number and Size (in.)	3 and 5/8
T-Slot Centers (in.)	2-1/2
Work Table Weight Capacity (lbs.)	720
Travel of Knee (in.)	14-1/4
Travel of Ram (in.)	20-1/2
Motor	3HP, 230/460V, 3Ph, Prewired 230V
Overall Dimensions (in./ L x W x H)	96 x 78 x 88
Net Weight (lbs.)	2,900



JTM-1050 MILL AND ACCESSORY PACKAGES INSTALLED

JTM-1050 with X Axis Powerfeed	690120
JTM-1050 with X & Y Axis Powerfeeds	690150
JTM-1050 with Acu-Rite VUE 2-Axis DRO & X-Axis Powerfeed	690403
JTM-1050 with Acu-Rite VUE 2-Axis DRO & X & Y-Axis Powerfeeds	690409
JTM-1050 with Acu-Rite 200S 2-Axis DRO & X-Axis Powerfeed	690117
JTM-1050 with Acu-Rite 200S 2-Axis DRO & X-Axis Powerfeed & Riser Block	690216
JTM-1050 with Acu-Rite 200S 2-Axis DRO & X-Axis Powerfeed, Air Draw Bar & Riser Block	690235
JTM-1050 with Acu-Rite 200S 2-Axis DRO & X & Y Axis Powerfeed	690214
JTM-1050 with Acu-Rite 200S 3-Axis DRO & X-Axis Powerfeed (Quill)	690158
JTM-1050 with Acu-Rite 200S 3-Axis DRO & X & Y-Axis Powerfeed (Quill)	690159
JTM-1050 with Acu-Rite 200S 3-Axis DRO & X & Y & Z Powerfeed (Quill)	690160
JTM-1050 with Acu-Rite 200S 3-Axis DRO & X & Y Powerfeed & Air Draw Bar (Quill)	690151
JTM-1050 with Acu-Rite 300S 2-Axis DRO & X-Axis Powerfeed	690306
JTM-1050 with Acu-Rite 300S 2-Axis DRO & X & Y Axis Powerfeed	690307
JTM-1050 with Newall DP700 2-Axis DRO	691204
JTM-1050 with Newall DP700 2-Axis DRO & Air Draw Bar	691172
JTM-1050 with Newall DP700 2-Axis DRO & X-Axis Powerfeed	691205
JTM-1050 with Newall DP700 2-Axis DRO & X & Y-Axis Powerfeeds	691206
JTM-1050 with Newall DP700 3-Axis DRO (Quill)	691207
JTM-1050 with Newall DP700 3-Axis DRO & X-Axis Powerfeed (Quill)	691208
JTM-1050 with Newall DP700 3-Axis DRO & X & Y-Axis Powerfeeds (Quill)	691209
JTM-1050 with Newall DP700 3-Axis DRO & X & Y & Z Powerfeed & Air Draw Bar (Quill)	690234
JTM-1050 with Newall DP700 3-Axis DRO & X-Axis Powerfeed (Knee)	691234
JTM-1050 with Newall DP700 3-Axis DRO & X & Y-Axis Powerfeeds (Knee)	691235



NEWALL DP700 - DRO



ACU-RITE 300S - DRO

JTM-4VS VARIABLE SPEED VERTICAL MILLING MACHINE

Constructed using the Meehanite® casting process, JET Variable Speed Milling Machines provide consistent and reliable operation. Precision bored and honed milling heads ensure quality cuts, and the three-stage power downfeed with automatic stop makes the JET Variable Speed Milling Machines easy to use. These machines deliver everything you've come to expect from JET, and so much more.



FEATURES

- Meehanite® casting
- Heavy-duty splined motor drive
- Three-stage power downfeed with automatic stop
- Adjustable gibs throughout
- Precision bored and honed milling head
- Large diameter quill is chromed
- High precision Class 7 spindle bearings
- Spindle head is internally cooled
- Satin chrome finished dials
- One-piece quill pinion and shaft
- Heavy-duty spindle brake
- Chrome plated motor shaft with lower bearing support
- Internal coolant tank built into base for use with coolant system (Coolant pump not included)
- Tolerance test sheet included

STANDARD EQUIPMENT

- Locks on all movable surfaces
- Precision hardened and ground ways and table
- One-shot lubrication system
- Way covers
- Draw bar
- Tool box with tools



ACU-RITE 2005 - DRO

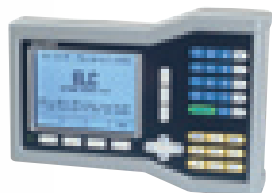

ACU-RITE VUE - DRO

STOCK NUMBER	690180	690182
Model Number	JTM-4VS-1	JTM-4VS
Table Size (in.)	9 x 49	9 x 49
Spindle Taper	R-8	R-8
Quill Diameter (in.)	3-3/8	3-3/8
Number of Spindle Speeds	Variable	Variable
Range of Spindle Speeds (RPM)	60 - 4,200	60 - 4,200
Quill Down Feed Rates (per./rev./in.)	.0015 - .003 - .006	.0015 - .003 - .006
Spindle Travel (in.)	5	5
Head Movement (deg.)	90° R & L, 45° F & B	90° R & L, 45° F & B
Max Distance Spindle to Table (in.)	17-1/2	17-1/2
Distance Spindle to Column (max./in.)	19	19
Distance Spindle to Column (min./in.)	4-1/2	4-1/2
Collet Capacity	1/8 - 7/8	1/8 - 7/8
Table Longitudinal Travel (in.)	34	34
Table Cross Travel (in.)	12	12
T-Slots Number and Size (in.)	3 and 5/8	3 and 5/8
T-Slot Centers (in.)	2-1/2	2-1/2
Work Table Weight Capacity (lbs.)	660	660
Travel of Knee (in.)	14-1/2	14-1/2
Travel of Ram (in.)	13-3/8	13-3/8
Motor	2HP, 115/230V, 1Ph, Prewired 230V	3HP, 230/460V, 3Ph, Prewired 230V
Overall Dimensions (in./ L x W x H)	66 x 63 x 85	66 x 63 x 85
Net Weight (lbs.)	2,420	2,420



690182 SHOWN WITH
OPTIONAL DRO AND
TABLE POWERFEED

JTM-4VS MILL AND ACCESSORY PACKAGES INSTALLED

JTM-4VS with X Axis Powerfeed	690183
JTM-4VS with Air Draw Bar	690119
JTM-4VS with X & Y Axis Powerfeeds	690008
JTM-4VS with X, Y & Z Axis Powerfeeds	690013
JTM-4VS with X & Y Axis Powerfeeds & Air Draw Bar	690009
JTM-4VS with Acu-Rite VUE 2-Axis DRO & X-Axis Powerfeed	690401
JTM-4VS with Acu-Rite VUE 2-Axis DRO & X-Axis Powerfeed & Air Draw Bar	690415
JTM-4VS with Acu-Rite VUE 2-Axis DRO & X & Y-Axis Powerfeeds	690420
JTM-4VS with Acu-Rite VUE 2-Axis DRO & X & Y & Z-Axis Powerfeeds	690417
JTM-4VS with Acu-Rite VUE 3-Axis DRO (Knee) & X-Axis Powerfeed	690408
JTM-4VS with Acu-Rite VUE 3-Axis DRO (Quill) & X & Y-Axis Powerfeeds	690416
JTM-4VS with Acu-Rite VUE 3-Axis DRO (Knee) & X & Y & Z-Axis Powerfeeds	690418
JTM-4VS with Acu-Rite 200S 2-Axis DRO	690202
JTM-4VS with Acu-Rite 200S 2-Axis DRO & X-Axis Powerfeed & Air Draw Bar	690125
JTM-4VS with Acu-Rite 200S 2-Axis DRO & X & Y Axis Powerfeed	690098
JTM-4VS with Acu-Rite 200S 2-Axis DRO & X & Y-Axis Powerfeed & Air Draw Bar	690230
JTM-4VS with Acu-Rite 200S 2-Axis DRO & X & Y & Z-Axis Powerfeed	690099
JTM-4VS with Acu-Rite 200S 3-Axis DRO (Quill)	690184
JTM-4VS with Acu-Rite 200S 3-Axis DRO & X-Axis Powerfeed (Quill)	690221
JTM-4VS with Acu-Rite 200S 3-Axis DRO & X-Axis Powerfeed & Air Draw Bar (Quill)	690251
JTM-4VS with Acu-Rite 200S 3-Axis DRO & X & Y-Axis Powerfeed (Quill)	690140
JTM-4VS with Acu-Rite 200S 3-Axis DRO & X & Y & Z Powerfeed (Quill)	690141
JTM-4VS with Acu-Rite 200S 3-Axis DRO & X & Y & Z Powerfeed & Air Draw Bar (Quill)	690153
JTM-4VS with Acu-Rite 300S 2-Axis DRO & X-Axis Powerfeed	690301
JTM-4VS with Acu-Rite 300S 2-Axis DRO & X & Y Axis Powerfeed	690302
JTM-4VS with Newall DP700 2-Axis DRO	691200
JTM-4VS with Newall DP700 2-Axis DRO & X-Axis Powerfeed	690087

JTM-4VS with Newall DP700 2-Axis DRO & X & Y-Axis Powerfeeds	691201
JTM-4VS with Newall DP700 3-Axis DRO (Quill)	691202
JTM-4VS with Newall DP700 3-Axis DRO & X-Axis Powerfeed (Quill)	690090
JTM-4VS with Newall DP700 3-Axis DRO & X & Y-Axis Powerfeeds (Quill)	691203
JTM-4VS with Newall DP700 3-Axis DRO & X-Axis Powerfeed (Knee)	691232
JTM-4VS with Newall DP700 3-Axis DRO & X & Y & Z Axis Powerfeed (Knee)	690093

JTM-4VS-1 MILL AND ACCESSORY PACKAGES INSTALLED

JTM-4VS-1 with X Axis Powerfeed	690178
JTM-4VS-1 with Acu-Rite VUE 2-Axis DRO & X-Axis Powerfeed	690402
JTM-4VS-1 with Acu-Rite VUE 2-Axis DRO & X & Y-Axis Powerfeeds	690407
JTM-4VS-1 with Acu-Rite VUE 3-Axis DRO (Quill) & X-Axis Powerfeed	690410
JTM-4VS-1 with Acu-Rite VUE 3-Axis DRO (Quill) & X & Y-Axis Powerfeeds	690413
JTM-4VS-1 with Acu-Rite VUE 3-Axis DRO (Knee) & X-Axis Powerfeed	690411
JTM-4VS-1 with Acu-Rite VUE 3-Axis DRO (Knee) & X & Y-Axis Powerfeeds	690412
JTM-4VS-1 with Acu-Rite 200S 2-Axis DRO & X-Axis Powerfeed	690179
JTM-4VS-1 with Acu-Rite 200S 3-Axis DRO & X & Y-Axis Powerfeed (Quill)	690068
JTM-4VS-1 with Acu-Rite 300S 2-Axis DRO & X-Axis Powerfeed	690303
JTM-4VS-1 with Acu-Rite 300S 3-Axis DRO & X & Y-Axis Powerfeed (Quill)	690118

CALL FOR ADDITIONAL PACKAGES

JTM-1/2 STEP PULLEY MILLING MACHINES

Three-stage power down feed with auto stop, high precision Class 7 spindle bearings and the rugged stability of Meehanite casting ensures you get everything you need from the JET JTM-1 and 2 models. The internally cooled spindle head prevents seizing, and JET precision engineering ensures superior results throughout this machine's long life.



FEATURES

- Meehanite® casting
- High precision Class 7 spindle bearings
- Heavy-duty splined motor drive
- Three-stage power downfeed with automatic stop
- Precision bored and honed milling head
- Large diameter quill is chromed
- Spindle head is internally cooled
- Satin chrome finished dials
- One-piece quill pinion and shaft
- Heavy-duty spindle brake

STANDARD EQUIPMENT

- One-shot lubrication system
- Way covers
- Draw bar
- Tool box with tools

STOCK NUMBER	690082	690089
Model Number	JTM-1	JTM-2
Table Size (in.)	9 x 42	9 x 42
Spindle Taper	R-8	R-8
Quill Diameter (in.)	3-3/8	3-3/8
Number of Spindle Speeds	16	8
Range of Spindle Speeds (RPM)	80 - 5,440	80 - 2,720
Quill Down Feed Rates (IPR)	.0015 - .003 - .006	.0015 - .003 - .006
Spindle Travel (in.)	5	5
Head Movement (deg.)	90° R & L, 45° F & B	90° R & L, 45° F & B
Max Distance Spindle to Table (in.)	17-1/2	17-1/2
Distance Spindle to Column (max./in.)	19	19
Distance Spindle to Column (min./in.)	4-1/2	4-1/2
Collet Capacity	1/8 - 7/8	1/8 - 7/8
Table Longitudinal Travel (in.)	23-7/8	23-7/8
Table Cross Travel (in.)	12-1/2	12-1/2
T-Slots Number and Size (in.)	3 and 5/8	3 and 5/8
T-Slot Centers (in.)	2-1/2	2-1/2
Work Table Weight Capacity (lbs.)	550	550
Travel of Knee (in.)	14-1/2	14-1/2
Travel of Ram (in.)	13-3/8	13-3/8
Motor	2HP, 230V, 3Ph	2HP, 115/230V, 1Ph, Prewired 230V
Overall Dimensions (in./ L x W x H)	57 x 64 x 82	57 x 64 x 82
Net Weight (lbs.)	2,200	2,200



JTM-1 MILL AND ACCESSORY PACKAGES INSTALLED

JTM-1 with X Axis Powerfeed	690019
JTM-1 with X Axis X & Y Axis Powerfeeds	690097
JTM-1 with X Axis Acu-rite VUE 2-Axis DRO	690280
JTM-1 with X Axis Acu-rite VUE 2-Axis DRO & X-Axis Powerfeed	690281
JTM-1 with X Axis Acu-rite VUE 2-Axis DRO & X & Y-Axis Powerfeeds	690282
JTM-1 with X Axis Acu-Rite 200S 2-Axis DRO	690244
JTM-1 with X Axis Acu-Rite 200S 2-Axis DRO & X-Axis Powerfeed	690168
JTM-1 with X Axis Acu-Rite 200S 2-Axis DRO & X & Y Axis Powerfeed	690161
JTM-1 with X Axis Newall DP700 2-Axis DRO	691187
JTM-1 with X Axis Newall DP700 2-Axis DRO & X-Axis Powerfeed	691188
JTM-1 with X Axis Newall DP700 2-Axis DRO & X & Y-Axis Powerfeeds	691189
JTM-1 with X Axis Newall DP700 3-Axis DRO (Quill)	691190
JTM-1 with X Axis Newall DP700 3-Axis DRO & X-Axis Powerfeed (Quill)	691191
JTM-1 with X Axis Newall DP700 3-Axis DRO & X & Y-Axis Powerfeeds (Quill)	691192
JTM-1 with X Axis Newall DP700 3-Axis DRO (Knee)	691196

JTM-2 MILL AND ACCESSORY PACKAGES INSTALLED

JTM-2 with X Axis Powerfeed	690006
JTM-2 with X & Y Axis Powerfeeds	690017
JTM-2 with Acu-rite VUE 2-Axis DRO	690283
JTM-2 with Acu-rite VUE 2-Axis DRO & X-Axis Powerfeed	690286
JTM-2 with Acu-rite VUE 2-Axis DRO & X & Y-Axis Powerfeeds	690285
JTM-2 with Acu-Rite 200S 2-Axis DRO & X-Axis Powerfeed	690114
JTM-2 with Acu-Rite 200S 2-Axis DRO & X & Y Axis Powerfeed	690210
JTM-2 with Acu-Rite 200S 3-Axis DRO & X-Axis Powerfeed (Quill)	690072
JTM-2 with Acu-Rite 200S 3-Axis DRO & X & Y-Axis Powerfeed (Quill)	690157
JTM-2 with Acu-Rite 200S 3-Axis DRO (Knee)	69088
JTM-2 with Newall DP700 2-Axis DRO	691193
JTM-2 with Newall DP700 2-Axis DRO & X-Axis Powerfeed	691194
JTM-2 with Newall DP700 2-Axis DRO & X & Y-Axis Powerfeeds	691195
JTM-2 with Newall DP700 3-Axis DRO (Quill)	691197
JTM-2 with Newall DP700 3-Axis DRO & X-Axis Powerfeed (Quill)	691198
JTM-2 with Newall DP700 3-Axis DRO & X & Y-Axis Powerfeeds (Quill)	691199

CALL FOR ADDITIONAL PACKAGES

JVM-836-1/3 STEP PULLEY MILLING MACHINE

Precision bored and honed milling head ensures your JET mill retains its tolerances for precision results throughout the life of your machine. Locks on all moveable parts protect against accidents. An industry-leading Two Year Warranty illustrates just how confident JET is in every piece of equipment we deliver.



FEATURES

- Precision bored and honed milling head
- High precision spindle bearings
- Over 10" of front to back ram travel
- Large diameter quill is chromed
- Locks on all movable surfaces
- Hardened and ground precision table
- Head tilts left or right

STANDARD EQUIPMENT

- One-shot lubrication system
- Way Covers
- Draw bar
- Tool box and tools

STOCK NUMBER	690036	690038
Model Number	JVM-836-1	JVM-836-3
Table Size (in.)	7-7/8 x 35-3/4	7-7/8 x 35-3/4
Spindle Taper	R-8	R-8
Quill Diameter (in.)	3-3/8	3-3/8
Number of Spindle Speeds	5	10
Range of Spindle Speeds (RPM)	240 - 1,550	120 - 1,550
Spindle Travel (in.)	5	5
Head Movement (deg.)	90° R & L	90° R & L
Max Distance Spindle to Table (in.)	13-3/4	13-3/4
Distance Spindle to Column (max./in.)	15-3/4	15-3/4
Distance Spindle to Column (min./in.)	5-1/4	5-1/4
Collet Capacity	1/8 - 7/8	1/8 - 7/8
Table Longitudinal Travel (in.)	22-1/4	22-1/4
Table Cross Travel (in.)	9-1/2	9-1/2
T-Slots Number and Size (in.)	3 and 5/8	3 and 5/8
T-Slot Centers (in.)	2-1/2	2-1/2
Work Table Weight Capacity (lbs.)	500	500
Travel of Knee (in.)	14	14
Travel of Ram (in.)	10-1/2	10-1/2
Motor	1-1/2HP, 115/230V, 1Ph, Prewired115V	1-1/2HP, 230V Only, 3Ph
Overall Dimensions (in./ L x W x H)	55 x 52 x 78	55 x 52 x 78
Net Weight (lbs.)	1,617	1,610



JVM-836-1 MILL AND ACCESSORY PACKAGES INSTALLED

JVM-836-1 with X Axis Powerfeed	690156
JVM-836-1 with X & Y Axis Powerfeeds	690211
JVM-836-1 with Acu-Rite VUE 2-Axis DRO	690239
JVM-836-1 with Acu-Rite VUE 2-Axis DRO & X-Axis Powerfeed	690198
JVM-836-1 with Acu-Rite VUE 2-Axis DRO & X & Y-Axis Powerfeeds	690212
JVM-836-1 with Acu-Rite VUE 3-Axis DRO (Quill) & X-Axis Powerfeed	690213
JVM-836-1 with Acu-Rite 200S 2-Axis DRO	690177
JVM-836-1 with Acu-Rite 200S 2-Axis DRO & X-Axis Powerfeed	690144
JVM-836-1 with Acu-Rite 200S 2-Axis DRO & X & Y Axis Powerfeed	690162
JVM-836-1 with Newall DP700 2-Axis DRO	691173
JVM-836-1 with Newall DP700 2-Axis DRO & X-Axis Powerfeed	691174
JVM-836-1 with Newall DP700 2-Axis DRO & X & Y-Axis Powerfeeds	691175
JVM-836-1 with Newall DP700 3-Axis DRO (Quill)	691176
JVM-836-1 with Newall DP700 3-Axis DRO & X-Axis Powerfeed (Quill)	691177
JVM-836-1 with Newall DP700 3-Axis DRO & X & Y-Axis Powerfeeds (Quill)	691178
JVM-836-1 with Newall DP700 3-Axis DRO (Knee)	691228

JVM-836-3 MILL AND ACCESSORY PACKAGES INSTALLED

JVM-836-3 with X Axis Powerfeed	690174
JVM-836-3 with X & Y Axis Powerfeeds	690175
JVM-836-3 with Acu-Rite VUE 2-Axis DRO	690191
JVM-836-3 with Acu-Rite VUE 2-Axis DRO & X-Axis Powerfeed	690194
JVM-836-3 with Acu-Rite 200S 2-Axis DRO	690190
JVM-836-3 with Acu-Rite 200S 2-Axis DRO & X-Axis Powerfeed	690146
JVM-836-3 with Newall DP700 2-Axis DRO	691179
JVM-836-3 with Newall DP700 2-Axis DRO & X-Axis Powerfeed	691180
JVM-836-3 with Newall DP700 2-Axis DRO & X & Y-Axis Powerfeeds	691183
JVM-836-3 with Newall DP700 3-Axis DRO (Quill)	691184
JVM-836-3 with Newall DP700 3-Axis DRO & X-Axis Powerfeed (Quill)	691185
JVM-836-3 with Newall DP700 3-Axis DRO & X & Y-Axis Powerfeeds (Quill)	691186

CALL FOR ADDITIONAL PACKAGES

JMD MILLING DRILLING MACHINES

Mill drills are a lighter alternative to a milling machine. These combine a belt driven drill press with the dual coordinate abilities of the milling machine's table for flexibility and efficiency. A locking collet prevents the cutting tool from falling away from the spindle when lateral forces are experienced against the bit. Although light in construction, the JMD Milling Drilling Machines possess the advantages of space-saving versatility, affordability and light machining capability.



FEATURES

- One-piece cast iron column for added support
- UL Listed motor
- New positive quick-stop knob and easy-to-read internal depth gauge (external on JMD-15)
- Forward and reverse switch on JMD-18
- Belt cover – quick slide latch allows faster belt adjustment to change spindle speeds

STANDARD EQUIPMENT

- Worklamp
- Adjustable carbide facemill
- Drill press angle vise
- 1/2" drill chuck, chuck arbor
- Draw bar
- Drill chuck guard



NEW DRILL CHUCK SAFETY SHIELD ON THE JMD-18

STOCK NUMBER	350017	350018	350020
Model Number	JMD-15	JMD-18	JMD-18PFN
Drilling Capacity (in.)	1	1-1/4	1-1/4
Face Mill Capacity (in.)	2-1/2	3	3
End Mill Capacity (in.)	1/2	3/4	3/4
Swing (in.)	14-1/2	15-7/8	15-7/8
Max Distance Spindle to Table (in.)	15	18	26
Spindle Taper	R-8	R-8	R-8
Spindle Travel Manual (in.)	3-1/2	5	5
Spindle Travel Auto (in.)	-	-	4-1/4
Quill Diameter (in.)	2-7/16	3	3
Column Diameter (in.)	3-5/8	4-1/2	4-1/2
Number of Spindle Speeds	12	12	12
Range of Spindle Speeds (RPM)	110 - 2,580	150 - 3,000	150 - 3,000
Max. Table Travel (in.)	14	20-1/2	20-1/2
Cross Travel (in.)	5-1/2	6-1/2	6-1/2
Working Surface of Table (in.)	7-1/2 x 23	9-1/2 x 32-1/4	9-1/2 x 32-1/4
T-Slots, Number and Size (in.)	4 and 9/16	4 and 5/8	4 and 5/8
T-Slot Centers (in.)	1-13/16	1-13/16	1-13/16
Base Dimensions (in.)	12-1/2 x 19-3/4	15-3/4 x 23-3/4	15-3/4 x 23-3/4
Motor (UL Listed)	1HP, 1Ph, 115/230V Prewired 115V	2HP, 115/230V Prewired 115V	2HP, 1Ph, 230V Only
Overall Dimensions (in./ L x W x H)	38 x 37-1/2 x 42	47 x 40 x 51	47 x 40 x 51
Net Weight (lbs.)	370	580	600

350018
SHOWN WITH
OPTIONAL STAND
350045



MILL / DRILL PACKAGES	STOCK NUMBER
JMD-18 Mill/Drill w/Acu-Rite VUE	350401
JMD-18PFN Mill/Drill w/Acu-Rite VUE	350402

OPTIONAL EQUIPMENT	STOCK NUMBER
Stand with Enclosed Shelf	350045
Powerfeed (JMD-18, 18PF Only)	350083
Clamping Kit for JMD-18 & JMD-18PFN	660038



660012



ACU-RITE VUE - DRO

ACCESSORIES

JET has the tool kits and accessories you need to ensure superior performance of your Milling Machine.



MILLING TOOL KITS

660220 24 PC. MILLING TOOL KIT FOR R8-SPINDLE MILLING MACHINES INCLUDES:

- 5 pc Wiggler Set
- 5pc 1/2" HSS Boring Bars
- 1pc Drill Drift
- 3pc Edge Finders
- 1pc Arbor JT6 to R8
- 1pc Adapter R8 to MT3
- 1pc 3/4" Shank
- 1pc 3/4" Boring Head
- 3pc. Hex Keys
- 1pc 2-1/2" Fly Cutter
- 1pc 3/8 x 3" Square Tool Bit
- 1pc Blank R8 Arbor



660100KT MILLING ACCESSORY KIT INCLUDES:

- 650132 Collet Set CS-R8, 6 pc. R-8 Collet Set 1/8" - 3/4" by 1/8ths for Mills
- 660012 Clamping Kit includes metal storage tray can be mounted on machine or wall, Three complete sets to choose from 52 pc. kit includes: Six T-slot nuts
- 660220 Tooling Kit 24 pc. Milling Tool Kit for R8-Spindle Milling Machines and 63186 Verti-lock Machine Vise

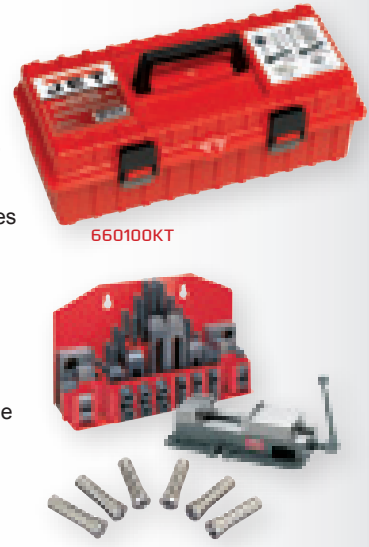

MILLING CHUCK AND COLLET SETS

- 17 pc. set in a wooden case
- Can quickly change from one shank size to another without loosening the draw bar
- 15 precision spring collets take the place of 15 individual adaptors
- Can be used for milling, drilling, reaming and boring operations
- Complete with spanner wrenches
- Collets are in increments of 1/16"
- T.I.R. at 2-3/8" is 0.0008"

STOCK NUMBER	466001
Model Number	CCS-1
Shank Taper	R-8
Capacity (in.)	1/8- 1



R8 COLLET SETS AND RACKS

- Precision hardened and ground
- Premium collets with 0.0005mm T.I.R.
- R8 Collets for use on milling machines

STOCK NO.	DESCRIPTION
650132	CS-R8, 6 pc. R-8 Collet Set 1/8" - 3/4" by 1/8ths for Mills
650133	6 pc. Premium R-8 Collet Set 1/8"-3/4" by 1/8th with Rack
650135	19 pc. Premium R-8 Collet Set 2mm - 20mm by 1mm with Rack
650136	Metal Collet Rack holds 12 R8 Collets
650137	Metal Collet Rack holds 48 R8 Collets
650138	Wooden Collet Rack holds 14 R8 Collets



TiN COATED END MILL SETS

- TiN (Titanium Nitride) coating provides extreme hardness and heat resistance allowing tool to run at higher speeds and feeds.
- Excellent for general-purpose use as TiN provides higher lubricity for freer chip flow, reduced buildup edge formations and catering.
- Square end mill types are used for general milling applications

STOCK NUMBER	DESCRIPTION
650210	20 PC TiN Coated Double End Mill Set 3/16-3/4" by 16ths 1 ea 2 & 4 flute
650211	20 PC TiN Coated Single End Mill Set 3/16-3/4" by 16ths 1 ea 2 & 4 flute



CLAMPING KITS

- Metal storage tray can be mounted on machine or wall
- Three complete sets to choose from
- 52 pc. kit includes: Six T-slot nuts, Six Flange nuts, Four Coupling nuts, Six Step blocks, Six Step clamps, Twenty four Studs, four each (3", 4", 5", 6", 7" & 8" lengths)

STOCK NUMBER	660038	660012	660058
Model No.	CK-38	CK-12	CK-58
Stud Size	3/8" - 16 T.P.I.	1/2" - 13 T.P.I.	5/8" - 11 T.P.I.
T-Slot Sizes (in.)	7/16 and 1/2	9/16 and 5/8	11/16 and 3/4

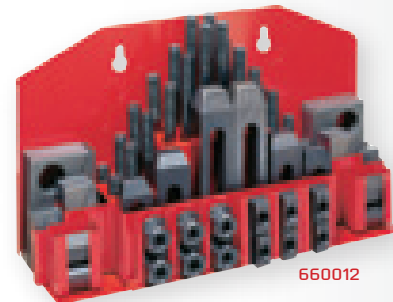

1-2-3 BLOCK SET

- Squareness: 0.0001"
- Parallelism: 0.0001"
- Height accuracy in pairs +/- 0.0001"
- Hardness HRC 56-60
- 5 pc. 3/8" - 16 socket head cap screws
- 1 pc. Hex Key
- Plastic Case

STOCK NUMBER	DESCRIPTION
630400	1-2-3 Block Set in Plastic Case

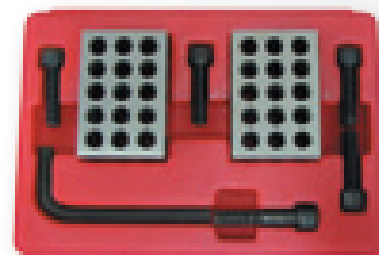

ACCESSORIES

Premier accessories enhance the flexibility and efficiency of your JET Mill.



TABLE AND KNEE POWERFEEDS

- Specially designed for each model
- X-, Y-, and Z-axis available
- Provides continuously variable feed rate of up to 32 in./min.
- Adjustable stops allow automatic shut off
- Includes rapid traverse button
- Built-in clutch helps prevent damage in overload
- Factory installation available
- Installation of powerfeed will reduce table travel

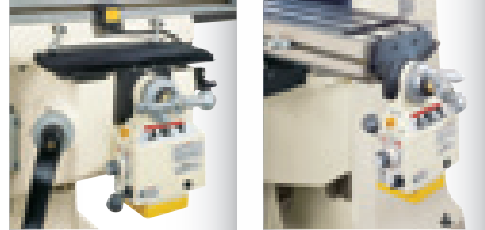

STOCK NO.	350194	350195	350197
Model No.	TPFA-2XN	TPFA-2YN	TPFA-2Z
Speed Rate/Variable (IPM)	0-32	0-32	0-32
Torque (in./lbs.)	780	780	780
Rapid Traverse (IPM)	32	32	32
Motor	105W /1AMP, 115V, 1 Ph	105W /1AMP, 115V, 1 Ph	105W /1AMP, 115V, 1 Ph
Net Weight (lbs.)	14	14	14

TO FIT MILL:	STOCK NO. X-AXIS	STOCK NO. Y-AXIS	STOCK NO. Z-AXIS
JVM-836	350194	350195	350197
JTM-1&2	350194	350195	350197
JTM-4VS	350194	350195	350197
JTM-1050	350194	350195	350197
JTM-1050EVS	350194	350195	350197
JTM-1055	350194	350195	350197

SWING AWAY ADJUSTABLE SAFETY SHIELD

These shields are intended to deflect chips, sparks, coolant or lubricant away from the operator and other employees in the machine area. They offer excellent visibility to the point of operation to help increase worker safety. The adjustable shields easily swing in or out of position.



STOCK NUMBER	DESCRIPTION
A635	Safety Shield

6 IN. JET DIAL CALIPER

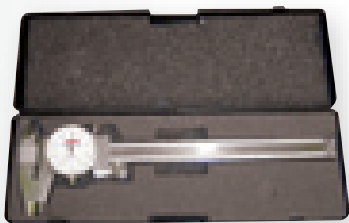

STOCK NUMBER	DESCRIPTION
650400	1pc Jet Brand 6"x0.001 Dial Caliper in Plastic Case

3 PIECE MEASURING TOOL KIT

- 1pc Jet Brand 0-6"x0.001 Dial Caliper
- 1pc Digital Counter Outside Micrometer 0-1x0.0001"
- 1pc Test Indicator 0.03x0.0005"



STOCK NUMBER	DESCRIPTION
650405	3 Piece Measuring Tool Kit



FLOOD COOLANT SYSTEM FOR MILLING MACHINES

Air and coolant line connections are encased in braided metal wire. One gallon tank is made of enamel paint finished metal with removable corrosion resistant inner liner.

STOCK NUMBER	DESCRIPTION
A619	Flood Coolant System for Models 220V/440V, 3Ph



RISER BLOCKS

FEATURES

- Specially designed for each model
- Adds 6" – 8" height capacity
- Includes all mounting hardware

STOCK NUMBER	MILL MODEL	SIZE (IN.)
350090	JTM-1&2	6
350090	JTM-4VS	6
350096	JTM-1050	8
350096	JTM-1050EVS	8



AIR POWER DRAW BAR

- Fits all JET variable speed milling machines
- High quality industrial grade air motor
- Double impact high torque design
- Easy installation requires no drilling or tapping
- Air requirements: 3 CFM at 90 PSI

STOCK NUMBER	MILL MODEL
A630	JTM-4VS
A630	JTM-1050
A630	JTM-1050EVS
A631	JTM-1055



ACU-RITE DRO SERIES FOR MILLING APPLICATIONS

Digital Readout packages for JET Machines keep track of position, provide prompt feedback and messaging, and quick configuration of machine features. Die-cast metal construction ensures unit reliability and displays are very easy to read. The days of inaccurate measurement conversions and productivity lulls caused by lost data are over - the right Digital Readout unit for the JET Mill in your shop is here.

ACU-RITE DROS COMMON FEATURES

- Job Clock
- Feed Rate Display
- Multiple Language Support
- Absolute/Incremental
- Near-Zero Warning



VUE

The Acu-Rite VUE is a cost-effective, entry-level solution for manual machine tool applications. With our innovative LCD display screen technology and versatile software to accommodate milling, turning or grinding applications the VUE is everything you need at a price you can afford.

VUE SPECIFIC FEATURES

- 1, 2 or 3 axes 5.7" Transmissive LCD display
- 200mm Fixed Reference Marks

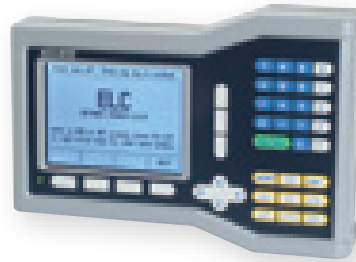

200S

As the industry standard in digital readout systems, the Acu-Rite 200S offers state-of-the-art features for milling, turning and grinding applications.

200S SPECIFIC FEATURES

- 2 or 3 axes 5.7" Transmissive LCD display
- Position-Trac™ Home Reference

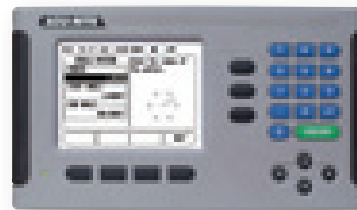

300S

The Acu-Rite 300S is a fully programmable 4 axes readout system, now available with a full color display. With the capability to store and create a library of programs the 300S is everything you need to create, edit and execute programs on your manual machine tool.

FEATURES

- 2, 3 or 4 axes 5.7" Full Color Display
- Position-Trac™ Home Reference
- Multiple program names with numerous steps

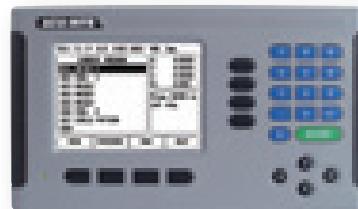

NEWALL DIGITAL READOUTS FOR MILLING APPLICATIONS

Add the latest in electronic design innovation to the JET Mill in your shop. Performs all essential functions and provides added flexibility to your operation.

NEWALL



DP700

The DP700 is the latest in Newall's line of a powerful and intuitive DROs. The unit is housed in a rugged, ergonomically designed casing. The DRO features all of the essential functions for milling, boring, turning, grinding, and general machining operations. The DP700 is compatible with Newall's Spherosyn and Microsyn encoders which withstand the harshest shop conditions.

FEATURES

- Feed Rate Display
- Bolt Hole Circle Routine
- Line Hole Routine
- Arc Contouring
- Programmable Memory/Teach
- Polar Coordinates
- Line Hole Calculator
- Tool Offsets
- Taper Calculations
- Axis Vectoring/Summing
- Linear and Segmented Error Comp.
- Undo
- RS232 Output
- Languages: English, French, German, Spanish, Italian, Turkish, Czech, Russian, Portuguese, Danish
- Clean, Crisp, Easy to Read, LEDs
- Intuitive Message Window
- Long Life Membrane Keypad
- Solid cast construction
- Safe, Low Voltage Power Supply (UL)
- Panel Mount Version Available

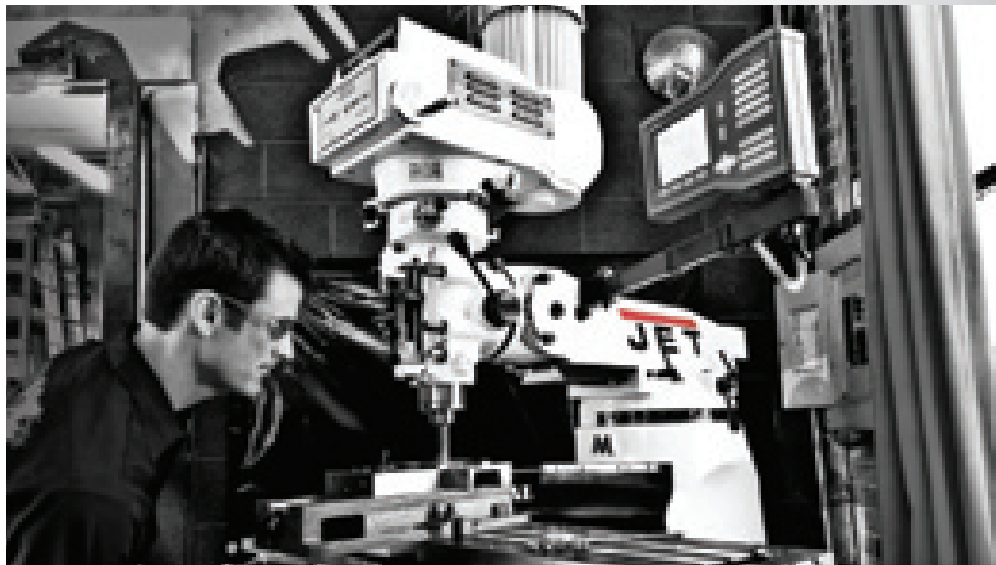

MILLING

MILLING HELPFUL INFO

JET STRIVES TO MAKE YOUR JOB EASIER. HERE IS SOME BASIC INFORMATION ABOUT ALL OUR MILLING MACHINES AND MILLING IN GENERAL TO HELP YOU GET STARTED.



OVERVIEW

Milling is the process of machining flat, curved, or irregular surfaces by feeding the workpiece against a rotating cutter containing a number of cutting edges. The mill consists basically of a motor driven spindle, which mounts and revolves the milling cutter, and a reciprocating adjustable worktable, which mounts and feeds the workpiece. The milling machine is excellent for forming flat surfaces, cutting dovetails and keyways, forming and fluting milling cutters and reamers, cutting gears, and so forth.

Most milling machines have self contained electric drive motors, coolant systems, step pulley or variable spindle speeds, and power operated table feeds.

Knee type mills are characterized by a vertical adjustable worktable resting on a saddle which is supported by a knee. The knee is a massive casting that rides vertically on the milling machine column and can be clamped rigidly to the column in a position where the milling head and milling machine spindle are properly adjusted vertically for operation.

The turret and swivel head assembly is designed for making precision cuts and can be swung 360 degrees on its base. Angular cuts to the horizontal plane may be made with precision by setting the head at any required angle within the 180 degree arc.

The knee is used for raising and lowering. The saddle rests upon the knee and supports the worktable. The saddle moves in and out on a dovetail to control the crossfeed of the worktable. The worktable traverses to the right or left upon the saddle for feeding the workpiece past the milling cutter. Many special operations can be performed with the attachments available for milling machine use.

JET Milling Machines are precision-built and designed to last. We have a full range of machines from Mill Drills, Step Pulley to Variable Speed models. All of JET's production mills are made with a Meehanite® casting and has it proudly stamped on the front of our machine! JET offers both R8 and NST-40 mills. JET will be happy to build your mill anyway you want it. JET installs Retrofit Acu-Rite MILLPWR controls is 2 or 3 axis, 2 or 3 Axis DRO's, Table or Knee Powerfeeds, Air Powered Draw Bars, Riser blocks for most models. If you do not see the package you need just give us a call.

JET CARRIES MANY ACCESSORIES TO GET YOUR MILL UP AND RUNNING WHEN IT HITS YOUR SHOP FLOOR. R-8 COLLET SETS, CLAMPING KITS, TOOLING KITS, AND 1-2-3 BLOCKS TO NAME A FEW.



MILL DRILLS

VARIABLE SPEED

STEP PULLEY



COMMON MILL TERMINOLOGY

- A** VERTICAL HEAD
- B** HEAVY-DUTY MOTOR DRIVE
- C** RAM
- D** HARDENED AND GROUND TABLE
- E** MEEHANITE® CASTING
- F** COLUMN
- G** SADDLE
- H** LOCKS ON ALL MOVEABLE SURFACES
- I** WAYS
- J** KNEE
- K** INTERNAL COOLANT TANK
- L** VERTICAL POSITIONING SCREW
- M** BASE

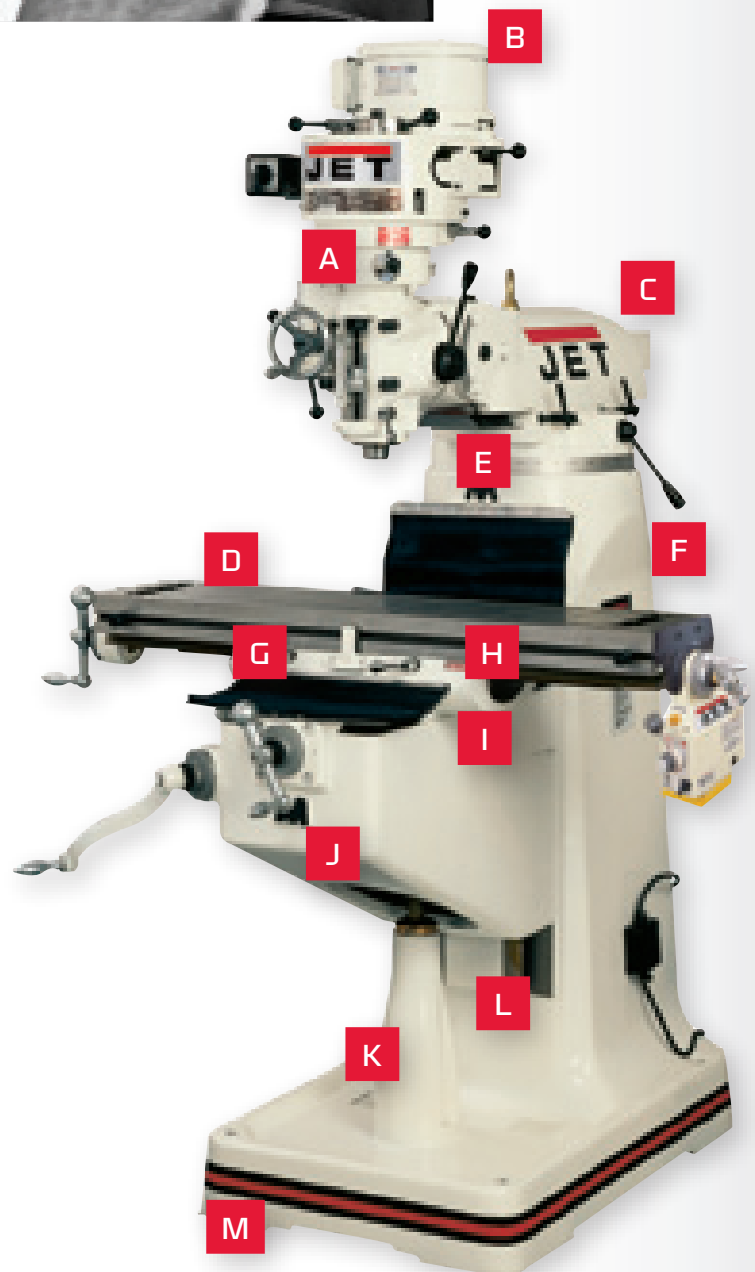



DRILLING

The complete line of JET Drill Presses delivers exact spacing and depth control. Engineered durability and enhanced flexibility, the perfect JET Drill Press for both commercial and maintenance operations is available. The industry's leading warranty and professional manuals for efficient operation assures every JET machine user that we back our products so you can put them to work with complete confidence.

CONFIDENCE WITH EVERY TURN OF THE HAND WHEEL



CONTENTS

ARM RADIAL DRILL PRESS	92 -95
DIRECT DRIVE DRILL PRESS	96
GEARED HEAD DRILL PRESS.	97-101
ELECTRONIC VARIABLE SPEED DRILL PRESSES.	102-105
BENCH AND FLOOR DRILL PRESSES	106-108
ACCESSORIES	109
DRILLING HELPFUL INFO.	110-111

5' ARM RADIAL DRILL PRESS

A geared head drill press delivers its power from the motor to the spindle through spur gearing located inside the machine's head, without the need for belts or other friction-causing elements. This design assures a positive drive at all times and minimizes maintenance requirements. The different gear ratios necessary to change the spindle speed are achieved through the use of levers located to one side of the head, and usually in conjunction with a two- or three-speed motor. JET offers some of the very best, backed by the industry-leading Two Year Warranty.



320038

FEATURES

- The power train gears and spline shaft are made of the finest quality, heat treated and ground nickel-chrome steel, giving extra strength and smoothness to high torque loads
- The spindle is made of the finest case hardened steel for extra strength and wear
- The spindle is supported by double row taper roller and thrust ball bearings at the nose, with thrust and radial axis bearings at the top
- The spindle is built to withstand exceptionally heavy drilling and boring loads and to insure maximum accuracy
- Push button controls are all reduced to 110V
- Electrical circuits are located in the built-in control box at the rear of the arm- this keeps the controls dust and humidity free while making them easily accessible for maintenance
- Entire frame is made of Meehanite® and high tensile strength cast iron to handle the heaviest of jobs
- Arm raising safety device prevents arm from dropping
- Counter balanced mechanism for spindle return
- 12 speeds/3 feed rates make exotic materials easier to drill, bore and tap
- Centralized control center
- Automatic tool ejector
- Hydraulic head and column clamping

STANDARD EQUIPMENT

- Built in work light
- Coolant pump
- Tool kit
- Box table

STOCK NUMBER	320038	320039
Model Number	J-1600R	J-1600R-4
Drilling Capacity Mild Steel (in.)	2-1/2	2-1/2
Drilling Capacity Cast Iron (in.)	2-5/16	2-7/8
Tapping Capacity Mild Steel (in.)	2	2
Tapping Capacity Cast Iron (in.)	2-3/8	2-3/8
Boring Capacity Steel (in.)	5	5
Boring Capacity Cast Iron (in.)	7-3/8	7-3/8
Column Diameter (in.)	17	17
Distance Column to Spindle (min/in.)	13-3/8	13-3/8
Distance Column to Spindle (max/in.)	62-1/4	62-1/4
Travel of Head Horizontal (in.)	44-7/8	44-7/8
Distance Base to Spindle (min/in.)	15	15
Distance Base to Spindle (max/in.)	63	63
Arm Travel Vertical (in.)	33-15/32	33-15/32
Table Dimensions (in.)	27-7/8 x 19-5/8 x 15-3/4	27-7/8 x 19-5/8 x 15-3/4
Base Dimensions (in.)	97-5/8 x 41-11/32 x 8-1/4	97-5/8 x 41-11/32 x 8-1/4
Quill Travel (in.)	14-9/16	14-9/16
Spindle Taper	MT-5	MT-5
Quill Travel w/ Powerfeed engaged (in.)	13	13
Number of Spindle speeds (RPM)	12 (40 - 1920)	12 (40 - 1920)
Quill Down feed Rates (IPR)	6 (.003 - .038 IPR)	6 (.003 - .038 IPR)
Motor	7-1/2HP, 230/460V, 3Ph, Prewired 230V	7-1/2HP, 460V, 3Ph
Elevating Motor	2HP	2HP
Coolant Pump Motor	1/8HP	1/8HP
Machine Height from Floor (in.)	125	125
Overall Dimensions (in./ LxWxH)	116 x 55 x 112	112 x 55 x 116
Net Weight (lbs.)	11000	11000

4' ARM RADIAL DRILL PRESSES

Another JET Drill Press designed to handle the large assignment. Everything on this 4' Arm Radial Drill Press is built to deliver smooth operation and withstand heavy loads for precision results. Rugged Meehanite frame ensures durability, giving your shop the ability to take on the biggest jobs that come your way.



320034

FEATURES

- The power train gears and spline shaft are made of the finest quality, heat treated and ground nickel-chrome steel, giving extra strength and smoothness to high torque loads
- The spindle is made of the finest case hardened steel for extra strength and wear
- The spindle is supported by double row taper roller and thrust ball bearings at the nose with trust and radial axis bearings at the top
- The spindle is built to withstand exceptionally heavy drilling and boring loads and to insure maximum accuracy
- Push button controls are all reduced to 110V
- Electrical circuits are located in the built-in control box at the rear of the arm- this keeps the controls dust and humidity free while making them easily accessible for maintenance.
- Entire frame is made of Meehanite® and high tensile strength cast iron to handle the heaviest of jobs

STANDARD EQUIPMENT

- Built in work light
- Coolant pump
- Tool kit
- Box table

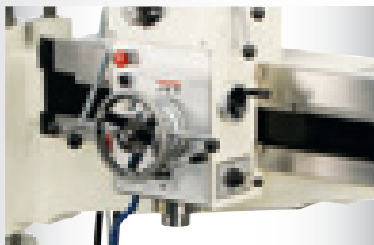

SPINDLE IS BUILT TO WITHSTAND EXCEPTIONALLY HEAVY DRILLING AND BORING LOADS TO ENSURE ACCURACY

STOCK NUMBER	320034	320035
Model Number	J-1100R	J1100R-4
Drilling Capacity Mild Steel (in.)	1-3/4	1-3/4
Drilling Capacity Cast Iron (in.)	2-1/4	2-1/4
Tapping Capacity Mild Steel (in.)	1	1
Tapping Capacity Cast Iron (in.)	1-1/4	1-1/4
Boring Capacity Steel (in.)	3-3/8	3-3/8
Boring Capacity Cast Iron (in.)	4-3/4	4-3/4
Column Diameter (in.)	10-1/4	10-1/4
Distance Column to Spindle (min/in.)	9-5/8	9-5/8
Distance Column to Spindle (max/in.)	43-5/16	43-5/16
Travel of Head Horizontal (in.)	32-1/4	32-1/4
Distance Base to Spindle (min/in.)	18-1/2	18-1/2
Distance Base to Spindle (max/in.)	50	50
Arm Travel Vertical (in.)	22-7/16	22-7/16
Table Dimensions (in.)	24-3/4 x 20-1/2 x 16-1/2	24-3/4 x 20-1/2 x 16-1/2
Base Dimensions (in.)	67-3/4 x 28 x 6-1/2	67-3/4 x 28 x 6-1/2
Quill Travel (in.)	9	9
Spindle Taper	MT-4	MT-4
Quill Travel w/ Powerfeed engaged (in.)	8-21/32	8-21/32
Number of Spindle speeds (RPM)	12 (44-1500)	12 (44 - 1500)
Quill Down feed Rates (IPR)	3 (.002, .004, .006)	3 (.002, .004, .006)
Motor	1-1/2 to 3HP, 230V, 3 Ph	1-1/2 to 3HP, 460V, 3 Ph
Elevating Motor	1HP	1HP
Coolant Pump Motor	1/8HP	1/8HP
Machine Height from Floor (in.)	100	100
Overall Dimensions (in./ LxWxH)	74 x 34 x 89	74 x 34 x 89
Net Weight (lbs.)	4190	4190

4' ARM RADIAL DRILL PRESSES

Another JET Drill Press designed to handle the large assignment. Everything on this 4' Arm Radial Drill Press is built to deliver smooth operation and withstand heavy loads to delivery precision results. Rugged Meehanite frame ensures durability, giving your shop the ability to take on the biggest jobs that come your way.



320036

FEATURES

- The power train gears and spline shaft are made of the finest quality, heat treated and ground nickel-chrome steel, giving extra strength and smoothness to high torque loads
- The spindle is made of the finest case hardened steel for extra strength and wear
- The spindle is supported by double row taper roller and thrust ball bearings at the nose with trust and radial axis bearings at the top
- The spindle is built to withstand exceptionally heavy drilling and boring loads and to insure maximum accuracy
- Push button controls are all reduced to 110V
- Electrical circuits are located in the built-in control box at the rear of the arm- this keeps the controls dust and humidity free while making them easily accessible for maintenance.
- Entire frame is made of Meehanite® and high tensile strength cast iron to handle the heaviest of jobs

STANDARD EQUIPMENT

- Built in work light
- Coolant pump
- Tool kit
- Box table



HANDWHEEL FOR HORIZONTAL GEARBOX TRAVEL

STOCK NUMBER	320036	320037
Model Number	J-1230R	J-1230R-4
Drilling Capacity Mild Steel (in.)	1-7/8	1-7/8
Drilling Capacity Cast Iron (in.)	2-5/16	2-5/16
Tapping Capacity Mild Steel (in.)	1	1
Tapping Capacity Cast Iron (in.)	1-1/2	1-1/2
Boring Capacity Steel (in.)	3-3/8	3-3/8
Boring Capacity Cast Iron (in.)	4-3/4	4-3/4
Column Diameter (in.)	11-13/16	11-13/16
Distance Column to Spindle (min/in.)	13-3/4	13-3/4
Distance Column to Spindle (max/in.)	46	46
Travel of Head Horizontal (in.)	35	35
Distance Base to Spindle (min/in.)	19-3/8	19-3/8
Distance Base to Spindle (max/in.)	54	54
Arm Travel Vertical (in.)	35	35
Table Dimensions (in.)	25 x 20-1/2 x 16-5/16	25 x 20-1/2 x 16-5/16
Base Dimensions (in.)	67-3/4 x 28 x 7	67-3/4 x 28 x 7
Quill Travel (in.)	9-7/8	9-7/8
Spindle Taper	MT-4	MT-4
Quill Travel w/ Powerfeed engaged (in.)	9-7/16	9-7/16
Number of Spindle speeds (RPM)	12 (44 - 1500)	12 (44 - 1500)
Quill Down feed Rates (IPR)	3 (.002, .004, .006)	3 (.002, .004, .006)
Motor	2-1/2 to 5HP, 230V, 3 Ph	2-1/2 to 5HP, 460V, 3 Ph
Elevating Motor	1HP	1HP
Coolant Pump Motor	1/8HP	1/8HP
Machine Height from Floor (in.)	109-1/2	109-1/2
Overall Dimensions (in./ LxWxH)	80 x 39 x 89	80 x 39 x 89
Net Weight (lbs.)	4520	4520

3' ARM RADIAL DRILL PRESS

The apex of heavy-duty JET Radial Arm Drill Presses are built to create precision holes in huge pieces and enhance productivity in even the busiest commercial shops. Operation is enhanced with power spindle feed and coolant systems, safety features and ergonomic design. JET Radial Arm Drill Presses are built to deliver under even the most demanding drilling specifications, and hold material fast for superior performance.



FEATURES

- The power train gears and spline shafts are made of the finest quality, heat treated and ground nickel-chrome steel, giving extra strength and smoothness to high torque loads
- The spindle is made of finest case hardened steel, for extra strength and wear
- The spindle is supported by double row taper roller and thrust ball bearings at the nose, with thrust and radial axis bearings at the top
- Built to withstand exceptionally heavy drilling and boring loads to insure maximum accuracy

STANDARD EQUIPMENT

- Built in work light
- Coolant pump
- Tool kit
- Box table



HEAVY-DUTY GEAR BOX

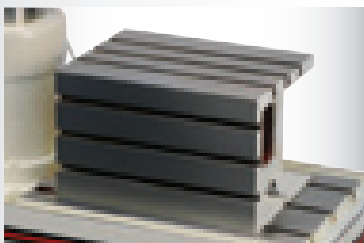

BOX TABLE STANDARD

STOCK NUMBER	320033
Model Number	J-720R
Drilling Capacity Mild Steel (in.)	1-1/2
Drilling Capacity Cast Iron (in.)	2
Tapping Capacity Mild Steel (in.)	3/4
Tapping Capacity Cast Iron (in.)	1
Boring Capacity Steel (in.)	2-3/8
Boring Capacity Cast Iron (in.)	4
Column Diameter (in.)	8-1/4
Distance Column to Spindle (min/in.)	8-5/8
Distance Column to Spindle (max/in.)	29-1/2
Travel of Head Horizontal (in.)	20-7/8
Distance Base to Spindle (min/in.)	9-5/8
Distance Base to Spindle (max/in.)	41-3/4
Arm Travel Vertical (in.)	23-13/16
Table Dimensions (in.)	23-5/8 X 17-1/2 X 15
Base Dimensions (in.)	49-5/8 x 25-3/16 x 6-1/4
Quill Travel (in.)	8-21/32
Spindle Taper	MT-4
Quill Travel w/ Powerfeed engaged (in.)	8-1/4
Number of Spindle speeds (RPM)	6 (88 - 1500)
Quill Down feed Rates (IPR)	.002, .004, .006
Motor	3HP, 230/460V 3Ph, Prewired 230V
Elevating Motor	1 HP
Coolant Pump Motor	1/8 HP
Machine Height from Floor (in.)	85-7/16
Overall Dimensions (in./ LxWxH)	64 x 32 x 85
Net Weight (lbs.)	2697

DIRECT DRIVE DRILL PRESSES

Shops must handle a wide variety of customer demands. This heavy-duty JET machine performs a variety of precision drilling and tapping applications. An easy-to-ready internal depth gauge prevents waste through errors, and a large production with T-slotted base holds over-sized pieces.



354050

FEATURES

- Direct drive round column drill press with mechanical clutch
- Two speed forward and reverse switch
- Mechanical powerfeed clutch engagement
- Heavy-duty quill and spindle
- Tempered, ground spindle with internal taper mounted in precision bearings for maximum accuracy, minimizing deflection
- Speed and feed selectors are located on one side of the drill head for convenience and ease of operation
- Oversized base is precision ground with T-slots for added versatility and stability

STANDARD EQUIPMENT

- Automatic tool ejector
- Manual quill lock
- Coolant system
- Low voltage at switch

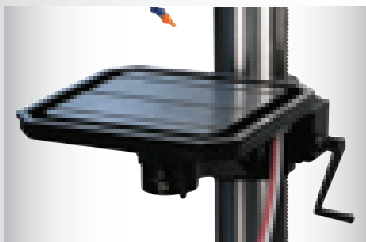
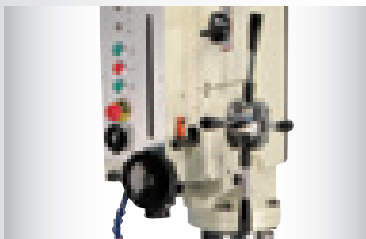

TABLE TILTS BOTH RIGHT & LEFT AND CAN BE ROTATED 360 DEGREES AROUND THE COLUMN FOR WIDER WORK AREA



SPEED AND FEED SELECTORS ARE LOCATED ON ONE SIDE OF THE DRILL FOR EASE OF OPERATION

STOCK NUMBER	354050	354051	354052
Model Number	J-2350	J-2360	J-2380
Drills to Center of Circle (in.)	28	30	33
Drilling Capacity Cast Iron (in.)	1-7/8	2-5/32	2-7/8
Drilling Capacity Mild Steel (in.)	1-3/4	2	2-3/4
Distance Column to Spindle (in.)	14	15	16-1/2
Range of Spindle Speeds (RPM)	82, 120, 180, 240, 354, 528, 678, 1026, 1524	55, 98, 156, 198, 346, 456, 576, 822, 1338	42, 58, 86, 116, 154, 249, 304, 412, 554, 748, 1098, 1458
Spindle Taper	MT-4	MT-4	MT-5
Spindle Travel (in.)	9	10	11
Spindle Distance to Base (in.)	49	50	51
Spindle Distance to Table (max./in.)	30-1/2	30-1/2	30-1/2
Table Size (in.)	22 x 19	22 x 19	23-1/2 x 23-1/2
T-Slots Number and Size (in.)	2 & 5/8	3 & 5/8	3 & 5/8
Work Table Weight Capacity (lbs.)	400	400	400
Base Dimensions (in./ LxWxH)	102 x 25 x 47	108 x 30 x 53	114 x 33 x 54
Base Slots Number & Size (in.)	3 & 5/8	3 & 5/8	3 & 5/8
Motor	3HP, 230/460V, 3 Ph, Prewired 230V	4HP, 230/460V, 3 Ph, Prewired 230V	7-1/2HP, 230/460V, 3 Ph, Prewired 230V
Floor Space Required (in./ LxWxH)	40 x 30 x 95	53 x 30 x 108	55 x 33 x 110
Net Weight (lbs.)	1810	2405	3065

26" JET/ARBOGA GEARED HEAD DRILL PRESS

This premier drill combines power and precision with a speed range of 108-1800 RPMs to handle virtually any drilling application. Driven by a sturdy 3HP motor, the drilling capabilities of up to 1-7/8" and tapping to 1" in steel! Exceptional support is provided by a large 5-1/2" steel column. Powerfeed engagement is controlled by one selector switch which makes this the perfect drill press for any shop.



354040

FEATURES

- Helical gears for smooth quiet operation
- Quick release drill ejector
- English/Metric depth gauge
- Machined, T-Slotted base plate
- No-volt release prevents spindle start when power returns after shut down
- Steel column
- Extra long quill movement
- Adjustable taper bearings mounted in the end of the quill
- Fiber & steel gears which do not require oil bath and allows for easy speed changes

STANDARD EQUIPMENT

- Fully enclosed spindle
- Large T-Slotted table



GEARS ARE A MIX OF FIBER AND STEEL WHICH RESULTS IN EASY SPEED CHANGES AND NO BELT SLIPPAGE



EXCEPTIONAL SUPPORT PROVIDED BY A LARGE 5-1/2" STEEL COLUMN

STOCK NUMBER	354040	354041
Model Number	J-A4008M-PF2	J-A4008M-PF4
Drills to Center Circle (in.)	26	26
Drilling Capacity Cast Iron (in.)	2	2
Drilling Capacity Mild Steel (in.)	1-7/8	1-7/8
Column Diameter (in.)	5-1/2	5-1/2
Distance Column to Spindle (in.)	13	13
Range of Spindle Speeds (RPM)	105, 162, 240, 360, 528, 805, 1175, 1800	105, 162, 240, 360, 528, 805, 1175, 1800
Spindle Taper	MT-4	MT-4
Spindle Travel (in.)	8	8
Spindle Distance to Base (in.)	44	44
Spindle Distance to Table (max./in.)	33	33
Table Size (in.)	15-3/4 x 19-3/4	15-3/4 x 19-3/4
Table Travel (in.)	25	25
T-Slots Number and Size (in.)	2 & 5/8	2 & 5/8
T-Slot Centers (in.)	8-1/4	8-1/4
Work Table Weight Capacity (lbs.)	550	550
Quill Feed	Auto	Auto
Quill Down Feed Rates (IPR)	.004, .006, .009, .013	.004, .006, .009, .013
Base Dimensions (in./ LxWxH)	23 x 28	23 x 28
Base Work Table (in.)	13 x 16-1/8	13 x 16-1/8
Base Slots Number & Size (in.)	2 & 5/8	2 & 5/8
Motor	3HP, 220V, 3Ph	3HP, 440/460V, 3Ph
Overall Dimensions (in./ LxWxH)	23 x 28 x 81	23 x 28 x 81
Net Weight (lbs.)	700	820

25" & 26" JET/ARBOGA GEARED HEAD DRILL PRESS

This durable drill press is ideal for any drilling application. For superior production, speed and accuracy the J-A3008M-PF models are equipped with a heavy-duty slip clutch powerfeed, which is automatically engaged when pre-set depths are reached. A heavy-duty t-slotted and machined base plate anchors this steady drill.



354034

FEATURES

- Helical gears for smooth, quiet operation
- Quick release drill ejector
- English/Metric depth gauge
- Machined, T-Slotted base plate
- Head and table rotate 360° around column
- No-volt release prevents spindle start when power returns after shut down
- Steel column
- Extra long quill movement
- Adjustable taper bearings mounted in the end of the quill
- Fiber & steel gears which do not required oil bath and allows for easy speed changes
- Drill head and table can be raised and lowered

STOCK NUMBER	354034	354035	354036	354037
Model Number	J-A3008-2	J-A3008-4	J-A3008M-PF2	J-A3008M-PF4
Drills to Center of Circle (in.)	26	26	25	25
Drilling Capacity Cast Iron (in.)	1-3/16	1-3/16	1-3/16	1-3/16
Drilling Capacity Mild Steel (in.)	31/32	31/32	31/32	31/32
Quill Feed	Manual	Manual	Auto	Auto
Quill Feed Rates (IRP)	-	-	.004, .006, .009, .12	.004, .006, .009, .12
Quill Travel (in.)	6	6	6	6
Quill Diameter (in.)	2-7/16	2-7/16	2-7/16	2-7/16
Range of Spindle Speeds (RPM)	90, 190, 320, 530, 640, 1060, 1790, 3610	90, 190, 320, 530, 640, 1060, 1790, 3610	90, 190, 320, 530, 640, 1060, 1790, 3610	90, 190, 320, 530, 640, 1060, 1790, 3610
Spindle Taper	MT-3	MT-3	MT-3	MT-3
Spindle Travel (in.)	6	6	6	6
Spindle Distance to Base (in.)	45-5/8	45-5/8	45-5/8	45-5/8
Spindle Distance to Table (max./in.)	35	35	35	35
Distance Column to Spindle (in.)	12-5/8	12-5/8	12-5/8	12-5/8
Table Size (in.)	15-3/4 x 19-3/4	15-3/4 x 19-3/4	15-3/4 x 19-3/4	15-3/4 x 19-3/4
Table Travel (in.)	30	30	30	30
T-Slots Number and Size (in.)	2 & 9/16	2 & 9/16	2 & 9/16	2 & 9/16
Work Table Weight Capacity (lbs.)	450	450	450	450
Base Dimensions (LxWxH/ in.)	28 x 24	28 x 24	28 x 24	28 x 24
Base Slots Number & Size (in.)	2 & 9/16	2 & 9/16	2 & 9/16	2 & 9/16
Motor	1-1/2 - 2HP, 220V, 3Ph	1-1/2 - 2HP, 440/460V, 3Ph	1-1/2 - 2HP, 220V, 3Ph	1-1/2 - 2HP, 440/460V, 3Ph
Overall Dimensions (in./ LxWxH)	28 x 24 x 72	28 x 24 x 72	28 x 24 x 72	28 x 24 x 72
Net Weight (lbs.)	565	565	600	600

20" JET/ARBOGA GEARED HEAD DRILL PRESS

A workhorse of a machine for precision production drilling applications. The head and table rotate 360 degrees around the column for maximum mobility. Eight drilling speeds provide high torque at lower speeds for both small and medium hole drilling. Special helical gears help maintain this drill's smooth, quiet operation.



354028

FEATURES

- Helical gears for smooth, quiet operation
- Quick release drill ejector
- Safety latch to prevent head dropping when unclamped
- Eight spindle speeds
- T-Slotted table with coolant trough
- Head and table rotate 360 degrees around column
- 2 position High/Low switch
- 3-15/16" Column diameter
- English/Metric depth gauge
- Both Head & Table can be raised or lowered
- Head and Table can be rotated 360 degrees
- Steel column
- Extra long quill movement
- Adjustable taper bearings mounted in the end of the quill
- Fiber & steel gears which do not require oil bath and allows for easy speed changes
- Drill head and table can be raised and lowered

STOCK NUMBER	354028	354029	354030	354031
Model Number	J-A2608-2	J-A2608-4	J-A2608M-PF2	J-A2608M-PF4
Drills to Center Circle (in.)	20	20	20	20
Drilling Capacity Cast Iron (in.)	1-3/8	1-3/8	1-3/8	1-3/8
Drilling Capacity Mild Steel (in.)	1-1/4	1-1/4	1-1/4	1-1/4
Column Diameter (in.)	3-15/16	3-15/16	3-15/16	3-15/16
Distance Column to Spindle (in.)	10	10	10	10
Range of Spindle Speeds (RPM)	Low-130, 260, 420, 840; High-535, 1070, 1745, 3480	Low-130, 260, 420, 840; High-535, 1070, 1745, 3480	Low-130, 260, 420, 840; High-535, 1070, 1745, 3480	Low-130, 260, 420, 840; High-535, 1070, 1745, 3480
Spindle Taper	MT-3	MT-3	MT-3	MT-3
Spindle Travel (in.)	5-1/8	5-1/8	5-1/8	5-1/8
Spindle Distance to Base (in.)	44	44	44	44
Spindle Distance to Table (max./in.)	35-5/8	35-5/8	35-5/8	35-5/8
Table Size (in.)	15-3/4 x 19-3/4	15-3/4 x 19-3/4	15-3/4 x 19-3/4	15-3/4 x 19-3/4
Quill Feed	Manual	Manual	Auto	Auto
Quill Feed Rates (IPR)	-	-	.0004, .006, .009, .012	.0004, .006, .009, .012
Quill Travel	5-1/8	5-1/8	5-1/8	5-1/8
Quill Diameter (in.)	2-3/8	2-3/8	2-3/8	2-3/8
Vertical Movement of Drill Head	8-5/8	8-5/8	8-5/8	8-5/8
Table Travel (in.)	24-1/2	24-1/2	24-1/2	24-1/2
T-Slots Number and Size (in.)	2 & 9/16	2 & 9/16	2 & 9/16	2 & 9/16
Work Table Weight Capacity (lbs.)	350	350	350	350
Base Dimensions (in./ LxWxH)	24 x 22	24 x 22	24 x 22	24 x 22
Motor	1 - 1-1/2HP, 220V, 3Ph	1 - 1-1/2HP, 440V, 3Ph	1 - 1-1/2HP, 220V, 3Ph	1 - 1-1/2HP, 440V, 3Ph
Overall Dimensions (in./ LxWxH)	24 x 22 x 72	24 x 22 x 72	24 x 22 x 72	24 x 22 x 72
Net Weight (lbs.)	475	475	600	600

20" GEARED HEAD DRILLING AND TAPPING PRESSES

Achieve precision drilling and tapping from a design that includes an easy-to-read internal depth gauge, three power down feeds, built-in spindle lock and calibrated fine down feed. JET backs this reliable combination drilling and tapping press with a Two Year Warranty.



354026

FEATURES

- Heavy-duty design allows a variety of precision drilling and tapping applications
- Easy to read internal depth gauge
- Three power down feeds
- Calibrated fine down feed built-in
- Built-in spindle lock
- Head tilts left or right
- Easy accessible table raiser
- Large production table and T-slotted base

STANDARD EQUIPMENT

- Integrated tapping and reversing controls
- T-slotted worktable
- Drill chuck arbor
- Draw bar
- TEFC Motor

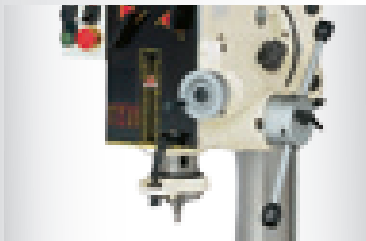

POWER DOWNFEED SPEED SELECTOR

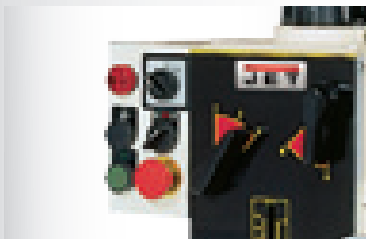

BOTH DRILLING & TAPPING WITH THE FLICK OF A SWITCH

STOCK NUMBER	354022	354026
Model Number	GHD-20T	GHD-20PFT
Drills to Center Circle (in.)	20	20
Drilling Capacity Cast Iron (in.)	1-1/2	1-1/2
Drilling Capacity Mild Steel (in.)	1-1/4	1-1/4
Tapping Capacity Mild Steel (in.)	15/16	15/16
Tapping Capacity Cast Iron (in.)	15/16	15/16
Column Diameter (in.)	4-1/2	4-1/2
Distance Column to Spindle (in.)	10	10
Range of Spindle Speeds (RPM)	120, 260, 460, 900, 1600, 3000, 60, 130, 230, 450, 800, 1500	120, 260, 460, 900, 1600, 3000, 60, 130, 230, 450, 800, 1500
Spindle Taper	MT-3	MT-3
Spindle Travel (in.) Manual	5	4-1/2
Spindle Travel (in.) Auto	N/A	4-1/4
Spindle Distance to Base (in.)	44-5/16	44-5/16
Spindle Distance to Table (max./in.)	30-1/2	30-1/2
Table Size (in.)	21-3/4 x 19-1/2	21-3/4 x 19-1/2
T-Slots Number and Size (in.)	2 & 5/8	2 & 5/8
T-Slot Centers (in.)	9	9
Work Table Weight Capacity (lbs.)	275	275
Base Dimensions (in./ LxWxH)	26 x 18 x 5	26 x 18 x 5
Base Work Table (in.)	15-1/4 x 13	15-1/4 x 13
Base Slots Number & Size (in.)	2 & 5/8	2 & 5/8
Motor	2HP, 230V, 3Ph, 2-speed	2HP, 230V, 3Ph, 2-speed
Overall Dimensions (in./ LxWxH)	32 x 24 x 71	32 x 24 x 71
Net Weight (lbs.)	700	708

20" GEARED HEAD DRILL PRESSES

JET Geared Head Drill Presses are ideal for repetitive drilling in a wide variety of materials. These drill presses are equipped with helical gears for smooth and quiet operation, a quick-release drill ejector and English/Metric depth gauge. T-slotted table, 8 spindle speeds, and a head and table that rotate 360° around the column enhance overall use and supply premier results.



FEATURES

- Heavy-duty design allows a variety of precision drilling applications
- Easy to read internal depth gauge
- Calibrated fine down feed built-in
- Built-in spindle lock
- Head tilts left or right
- Easy accessible table raiser
- Large production table and T-slotted base

STANDARD EQUIPMENT

- T-slotted worktable
- Drill chuck arbor
- Draw bar



FINE FEED ADJUSTMENT KNOB IN EASY TO REACH LOCATION

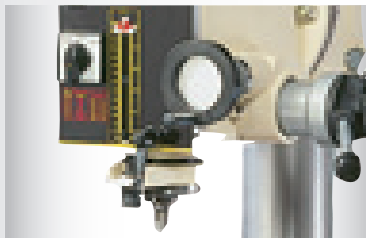

DEPTH STOP WHEN SET THE QUILL WILL ONLY ADVANCE TO THE SET DEPTH



354020

STOCK NUMBER	354020	354024
Model Number	GHD-20	GHD-20PF
Drills to Center Circle (in.)	20	20
Drilling Capacity Cast Iron (in.)	1-1/2	1-1/2
Drilling Capacity Mild Steel (in.)	1-1/4	1-1/4
Column Diameter (in.)	4-1/2	4-1/2
Distance Column to Spindle (in.)	10	10
Range of Spindle Speeds (RPM)	Low 60, 130, 230, 450, 800, 1500 High 120, 260, 460, 900, 1600, 3000	Low 60, 130, 230, 450, 800, 1500 High 120, 260, 460, 900, 1600, 3000
Spindle Taper	MT-3	MT-3
Number of Powerfeeds (GHD-20PF)		3
Spindle Travel (in.) Manual	5	4-1/2
Spindle Travel (in.) Auto	N/A	4-1/4
Spindle Distance to Base (in.)	44-15/16	44-15/16
Spindle Distance to Table (max./in.)	30-1/2	30-1/2
Table Size (in.)	21-3/4 x 19-1/2	21-3/4 x 19-1/2
T-Slots Number and Size (in.)	2 & 5/8	2 & 5/8
T-Slot Centers (in.)	9	9
Work Table Weight Capacity (lbs.)	275	275
Base Dimensions (in./ LxWxH)	26 x 18 x 5	26 x 18 x 5
Base Work Table (in.)	15-1/4 x 13	15-1/4 x 13
Base Slots Number & Size (in.)	2 & 5/8	2 & 5/8
Motor	2HP, 230V, 3Ph, 2 Speed	2 HP, 230V, 3 Ph, 2 Speed
Overall Dimensions (in./ LxWxH)	32 x 24 x 71	33 x 29 x 76
Net Weight (lbs.)	660	660

20" VARIABLE SPEED DRILL PRESSES

JET Electronic Variable Speed Drill Presses permit use at spindle revolution rates between 65 and 2000 RPM for a wide variety of applications. Designed to permit continuous speed adjustment - even during operation. Tapping, emergency stop and a heavy-duty casted head are but a few of the features JET includes to enhance overall use and accuracy.



FEATURES

- Variable spindle speed from 65 to 2000RPM
- MT-3 spindle taper
- Latest AC inverter variable speed technology
- High torque at all speeds both forward and reverse
- Continuous speed adjustment while in operation
- Front mounted LED spindle RPM readout
- Forward and reverse for tapping
- Emergency stop
- Front mounted positive control depth stop
- Large precision ground T-slot production table for easy set ups
- Heavy-duty casted head for more accuracy and rigidity



DRILLING CHART ADDED FOR OPERATOR EASE OF USE



LATEST AC INVERTER VARIABLE SPEED TECHNOLOGY



STOCK NUMBER	354214	354216
Model Number	J-2232AC	J-2234AC
Drilling Capacity Cast Iron (in.)	1-1/2	1-1/2
Drilling Capacity Mild Steel (in.)	1-3/8	1-3/8
Tapping Capacity Cast Iron (in.)	7/8	7/8
Tapping Capacity Mild Steel (in.)	3/4	3/4
Column Diameter (in.)	4-1/2	4-1/2
Distance Column to Spindle (in.)	10-7/16	10-7/16
Range of Spindle Speeds (RPM)	65 - 2000	65 - 2000
Spindle Travel (in.)	6	6
Spindle Distance to Base (in.)	43-5/16	43-5/16
Max Distance Spindle to Table (in.)	30-1/4	30-1/4
Table Size (in.)	18-1/8 x 14-3/4	18-1/8 x 14-3/4
Table Travel (in.)	18	18
T-Slots Number and Size (in.)	2 & 5/8	2 & 5/8
T-Slot Centers (in.)	7-7/16	7-7/16
Work Table Weight Capacity (lbs.)	176	176
Spindle Taper	MT-3	MT-3
Base Dimensions (in./ LxWxH)	27-1/2 x 19-1/4 x 6-1/8	27-1/2 x 19-1/4 x 6-1/8
Base Work Table (in.)	14-3/4 x 11-13/16	14-3/4 x 11-13/16
Base Slots Number & Size (in.)	2 & 5/8	2 & 5/8
Motor	2HP, 220V, 3Ph*	2HP, 460V, 3Ph
Overall Dimensions (in./ LxWxH)	37 x 27 x 80	37 x 27 x 80
Net Weight (lbs.)	792	792

*J-2232AC can also run as 220V, Single Phase

20" ELECTRONIC VARIABLE SPEED DRILL PRESSES

JET innovation for smooth, quiet operation that delivers superior results. This 20" EVS Drill Press line is among the very best you can add to your shop operation. When the job demands perfection, perfection is what you get when you put JET on the job.



354212

FEATURES

- Runs quieter and smoother than a conventional variable speed head
- 230V model can run on single phase power
- Low maintenance head has less moving parts
- Incorporates a high-low gear box to maintain low speed torque
- Chrome molybdenum gears are hardened, ground, and shaved
- Quiet running and longer life
- Speed can be adjusted in each range during operation
- LED spindle RPM readout is conveniently mounted
- Tapping mode allows instantaneous spindle reversal
- Easy to read internal depth gauge
- Extra large emergency stop button adds to safe operation
- Table can be raised from the front or side
- Large production table and T-slotted dish-in base

STANDARD EQUIPMENT

- Integrated tapping and reversing controls
- Complete coolant system
- T-slotted work table



COOLANT FOR DRILLING & TAPPING IS AS EASY AS A FLIP OF A SWITCH



LARGE, EASY TO READ DEPTH CHART

STOCK NUMBER	354210	354212
Model Number	JDP-20EVS/230	JDP-20EVS/460
Drills to Center Circle (in.)	20	20
Drilling Capacity Cast Iron (in.)	1-1/2	1-1/2
Tapping Capacity Cast Iron (in.)	7/8	7/8
Tapping Capacity Mild Steel (in.)	3/4	3/4
Drilling Capacity Mild Steel (in.)	1-3/8	1-3/8
Column Diameter (in.)	4-1/2	4-1/2
Distance Column to Spindle (in.)	10-7/16	10-7/16
Range of Spindle Speeds (RPM)	65 - 2000	65 - 2000
Spindle Taper	MT-3	MT-3
Spindle Travel (in.)	6	6
Spindle Distance to Base (in.)	43-5/16	43-5/16
Max Distance Spindle to Table (in.)	30-1/4	30-1/4
Table Size (in.)	18-1/8 x 14-3/4	18-1/8 x 14-3/4
Table Travel (in.)	18	18
T-Slots Number and Size (in.)	2 & 5/8	2 & 5/8
T-Slot Centers (in.)	7-7/16	7-7/16
Base Dimensions (in./ LxWxH)	27-1/2 x 19-1/4 x 6-1/8	27-1/2 x 19-1/4 x 6-1/8
Base Work Table (in.)	14-3/4 x 11-13/16	14-3/4 x 11-13/16
Base Slots Number & Size (in.)	2 & 5/8	2 & 5/8
Motor	2HP, 230V only, 3Ph	2HP, 460V only, 3Ph
Overall Dimensions (in./ LxWxH)	37 x 37 x 83	37 x 37 x 83
Net Weight (lbs.)	722	722

20" VARIABLE SPEED DRILL PRESSES

All the precision operation and control on a heavy-duty cast iron base. Variable speed spindles, front mounted positive control depth stop and other features that enhance overall operation make these JET 20" Variable Speed Drill Presses a machinist's first choice.



FEATURES

- Variable spindle speeds from 300 to 2000 RPM
- #3 Morse Taper
- Front mounted positive control depth stop
- 6" Quill travel
- Massive 3" quill diameter
- Heavy-duty cast iron design
- Large precision ground T-Slot production table for easy set ups
- Front or side rack and worm gear table raiser
- Table rotates 360° around the column
- Machined T-Slotted base
- Head is massively constructed for more accuracy and rigidity



FRONT OR SIDE RACK AND WORM GEAR TABLE RAISER

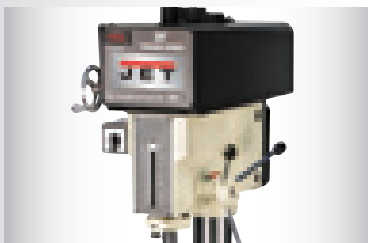

HEAD IS MASSIVELY CONSTRUCTED FOR ACCURACY AND RIGIDITY



354221

STOCK NUMBER	354221	354223
Model Number	J-2221VS	J-2223VS
Drills to Center Circle (in.)	20	20
Drilling Capacity Cast Iron (in.)	1-1/4	1-1/4
Drilling Capacity Mild Steel (in.)	1	1
Column Diameter (in.)	4-1/2	4-1/2
Distance Column to Spindle (in.)	10-7/16	10-7/16
Range of Spindle Speeds (RPM)	300 to 2000	300 to 2000
Spindle Travel (in.)	6	6
Spindle Distance to Base (in.)	43-5/16	43-5/16
Max Distance Spindle to Table (in.)	30-1/4	30-1/4
Table Size (in.)	18-1/8 x 14-3/4	18-1/8 x 14-3/4
Table Travel (in.)	18	18
T-Slots Number and Size (in.)	2 & 5/8	2 & 5/8
T-Slot Centers (in.)	7-7/16	7-7/16
Work Table Weight Capacity (lbs.)	176	176
Spindle Taper	MT-3	MT-3
Base Dimensions (in./ LxWxH)	27-1/2 x 19-1/4 x 6-1/8	27-1/2 x 19-1/4 x 6-1/8
Base Work Table (in.)	14-3/4 x 11-13/16	14-3/4 x 11-13/16
Base Slots Number & Size (in.)	2 & 5/8	2 & 5/8
Motor	2HP, 115/230V, 1Ph (Prewired 115V)*	2HP, 230/460V, 3Ph (Prewired 230V)*
Overall Dimensions (in./ LxWxH)	37 x 27 x 77	37 x 27 x 77
Net Weight (lbs.)	715	715

*Cord not provided as amprage is over 15A.

STOCK NUMBER	DESCRIPTION
5512104	Coolant system, 1/8HP pump, 115/220V, 1Ph
5508071	Coolant system, 1/8HP pump, 220/440V, 3Ph

15" VARIABLE SPEED DRILL PRESSES

These JET Drill Presses use a variable-speed motor with the stepped-pulley system, and come equipped with a continuously variable transmission. This enables use at a wide range of speeds, as well as the ability to change speed during operation. A scale-marked handwheel that matches the desired machine speed is mounted to a reduction gearing system for precise operator control of gap between the pulley halves. This gap control adjusts the gearing ratio between the motor's fixed pulley and the output shaft's variable pulley, changing the speed of the chuck. A tensioner pulley is implemented in the belt transmission to take up or release the slack in the belt as the speed changes.



FEATURES

- Speeds from 400 to 5000 RPM
- Handwheel adjustment sets the speeds
- Large 2-1/4" quill allows greater accuracy
- 3" Column diameter for maximum head support
- Full bearing support on quill for maximum spindle stiffness
- 6" stroke for deep hole application
- Accurate depth stop for precise hole depths
- 1/2" drill chuck & arbor
- Safety collar



1/2" DRILL CHUCK & ARBOR INCLUDED



EASY TO READ LED SPEED DISPLAY



354550

STOCK NUMBER	354550	354551
Model Number	J-A5816	J-A5818
Drills to Center Circle (in.)	15	15
Drilling Capacity Cast Iron (in.)	5/8	5/8
Drilling Capacity Mild Steel (in.)	1/2	1/2
Column Diameter (in.)	3	3
Distance Column to Spindle (in.)	7-1/2	7-1/2
Spindle Travel (in.)	6	6
Spindle Distance to Base (in.)	44-1/2	44-1/2
Max Distance Spindle to Table (in.)	25-3/4	25-3/4
Table Size (in.)	15 x 18	15 x 18
Table Travel (in.)	16-3/4	16-3/4
T-Slots Number and Size (in.)	2 & 1/2	2 & 1/2
T-Slot Centers (in.)	5-5/16	5-5/16
Work Table Weight Capacity (lbs.)	90	90
Spindle Taper	MT-2	MT-2
Range of Spindle Speeds (RPM)	400 - 5000	400 to 5000
Base Dimensions (in./ LxWxH)	20-7/16 x 14-3/16 x 3-1/8	20-7/16 x 14-3/16 x 3-1/8
Base Work Table (in.)	12-1/8 x 11-13/16	12-1/8 x 11-13/16
Base Slots Number & Size (in.)	2 & 1/2	2 & 1/2
Motor	1HP, 115/20V, 1Ph (Prewired 115V)	1HP, 230/460V, 3Ph (Prewired 230V)
Overall Dimensions (in./ LxWxH)	30 x 20 x 71	30 x 20 x 71
Net Weight (lbs.)	426	426

15" AND 20" DRILL PRESSES

Accuracy, stability and versatility are the benchmark features of the JET 15" and 20" Drill Presses.

This high quality line of JET Drill Presses offer a greater range in spindle speeds than other machines of this class. JET backs their machines with the industry-leading Two Year Warranty.



354401

354400

354402

FEATURES

- Cast iron head
- Large quill allows greater accuracy
- Head casting features a permanently lubricated ball bearing spindle assembly, using four heavy-duty ball bearings mounted in an enclosed quill for extended life
- Massive T-slotted production work table (Model J-2550 only)
- Table tilts 45°
- Large ground steel column diameter for maximum head and table support
- 3-1/8" stroke for deep hole applications (4-3/4" on model J-2550)
- Accurate depth stop for precise hole depths

STANDARD EQUIPMENT

- 5/8" Drill chuck and arbor



J-2550 HAS A MASSIVE T-SLOT PRODUCTION WORK TABLE AND BASE



ALL MODELS HAVE A CAST IRON HEAD FOR BETTER DRILLING ACCURACY

STOCK NUMBER	354401	354400	354402
Model Number	J-2530	J-2500	J-2550
Drills to Center Circle (in.)	15	15	20
Drilling Capacity Cast Iron (in.)	5/8	5/8	3/4
Drilling Capacity Mild Steel (in.)	1/2	1/2	5/8
Column Diameter (in.)	2-7/8	2-7/8	3-5/8
Distance Column to Spindle (in.)	7-1/2	7-1/2	10-1/2
Number of Speeds	16	16	12
Range of Spindle Speeds (RPM)	200, 290, 350, 430, 500, 580, 640, 720, 800, 870, 1440, 1630, 1820, 2380, 2540, 3630	200, 290, 350, 430, 500, 580, 640, 720, 800, 870, 1440, 1630, 1820, 2380, 2540, 3630	150, 260, 300, 440, 490, 540, 1150, 1550, 1840, 2220, 2950, 4200
Spindle Travel (in.)	3-3/8	3-3/8	4-3/4
Spindle Distance to Base (in.)	24	48	43-1/2
Spindle Distance to Table (max./in.)	15-1/2	24	24
Table Size (in.)	11-1/2 x 11-1/2	11-1/2 x 11-1/2	18-1/2 x 16-1/2
Table Travel (in.)	15-1/2	24	21-1/2
T-Slots Number and Size (in.)	N/A	N/A	3 x 1/2
T-Slot Centers (in.)	N/A	N/A	4
Work Table Weight Capacity (lbs.)	44	44	66
Spindle Taper	MT-2	MT-2	MT-3
Base Dimensions (LxW/ in.)	18 x 10-1/2	11 x 19-1/2	22-3/4 x 17-3/4
Base Work Table (in.)	8 x 8	7x 7-1/2	13 x 14-1/2
Motor	3/4HP, 115V, 1Ph,	3/4HP, 115V, 1Ph	1 HP, 115/230V, 1Ph, Prewired 115V
Overall Dimensions (in./ LxWxH)	31 x 13 x 39-1/2	31 x 13 x 63	33-1/2 x 18-1/2 x 67
Net Weight (lbs.)	157	167	304

20" FLOOR DRILL PRESS

This JET 20" Floor Drill Press is designed to allow rapid change of spindle speed, and comes equipped with a rotating and tilting crank-operated worktable with quick-release clamps. Machinists can put this Drill Press through the paces and receive superior results time after time. High-quality manufactured parts ensure long life.



FEATURES

- Hinged metal belt and pulley cover coupled with quick adjustment motor mount allow rapid changing of spindle speeds
- Rotating, 45° tilting, crank-operated worktable with quick release clamp
- On/off switch located on front of the drill press head
- A 1/2" diameter external positive depth stop with three nut locking feature for quick adjustment
- Adjustable tension spindle return spring
- Spindle is supported by high quality ball bearings
- Built-in work lamp on all models, bulb not included
- Drill chuck and key included



LARGE CAST IRON HEAD WITH EASY TO USE SPIDER HANDLE



1/2" DIAMETER EXTERNAL POSITIVE DEPTH STOP

STOCK NUMBER	354170
Model Number	JDP-20MF
Drills to Center Circle (in.)	20
Drilling Capacity Cast Iron (in.)	1
Drilling Capacity Mild Steel (in.)	3/4
Column Diameter (in.)	3-3/8
Distance Column to Spindle (in.)	10
Number of Speeds	12
Range of Spindle Speeds (RPM)	150-4200
Spindle Travel (in.)	4-5/8
Spindle Distance to Base (in.)	46-3/4
Max Distance Spindle to Table (in.)	29-1/8
Table Size (in.)	18-1/2 x 16
T-Slots Number and Size (in.)	6 & 1/2
T-Slot Centers (in.)	3-1/2
Work Table Weight Capacity (lbs.)	80
Spindle Taper	MT-3
Base Dimensions (in./ LxWxH)	13-3/4 x 22-3/4
Base Work Table (in.)	13 x 8-1/2
Base Slots Number & Size (in.)	2 & 5/8
Motor	1-1/2HP, 115/230V, 1Ph (Prewired 115V)
Overall Dimensions (in./LxWxH)	31-1/2 x 18-1/2 x 66
Net Weight (lbs.)	282

15" 6-SPEED DRILL PRESS

JET's heavy-duty 6-speed Step Pulley Drill Press are manufactured with the weight and rigidity to maintain the tight tolerances required of metalworking applications. The oversized, massive drill heads have widely spaced bearing surfaces for full quill support throughout its travel. JET included a wider range of operation speeds for drilling both small and larger holes with quick and easy speed changes.



FEATURES

- Constructed to provide a solid base for drilling
- Offers a greater range in spindle speeds than others in this class
- Larger quill provides greater accuracy
- Large production work table gives the operator the room to work and support for the job
- 3" Column for head support, while the quill is also supported to lessen deflection

STANDARD EQUIPMENT

- 1/2" Drill chuck and arbor
- Drill chuck guard



LARGE PRODUCTION WORK TABLE



3" COLUMN FOR HEAD SUPPORT

STOCK NUMBER	354500
Model Number	J-A3816
Drills to Center Circle (in.)	15
Drilling Capacity Cast Iron (in.)	5/8
Drilling Capacity Mild Steel (in.)	1/2
Column Diameter (in.)	3
Distance Column to Spindle (in.)	15
Range of Spindle Speeds (RPM)	375, 625, 1125, 1950, 3400, 5000
Spindle Travel (in.)	6
Spindle Distance to Base (in.)	44-1/2
Max Distance Spindle to Table (in.)	25-3/4
Table Size (in.)	15 x 18
Table Travel (in.)	16-3/4
T-Slots Number and Size (in.)	2 & 1/2
T-Slot Centers (in.)	5-5/16
Work Table Weight Capacity (lbs.)	90
Spindle Taper	MT-2
Base Dimensions (LxWxH/ in.)	20-7/8 x 14-3/16 x 3-1/8
Base Work Table (in.)	12-1/8 x 1-13/16
Base Slots Number & Size (in.)	2 & 1/2
Motor	1HP, 115/230V, 1Ph, Prewired 115V
Overall Dimensions (in./ LxWxH)	30 x 20 x 71
Net Weight (lbs.)	394

ACCESSORIES

JET designs all our Drill Presses for optimal use, but we know your job requires flexibility and versatility. A complete line of accessories are available to ensure your JET Drill Press is equipped to do exactly what you need, when you need it.



TAPER MOUNT DRILL CHUCKS

FEATURES

- All components are heat-treated high grade alloy steel
- Chuck jaws are precision fitted to withstand 115 PSI of torque
- All models meet JIS specifications: B4634E



STOCK NUMBER	TDC-375	TDC-500	TDC-501	TDC-625	TDC-750
Model Number	561702	561704	561706	561708	561709
Capacity (in.)	0 - 3/8	0 - 1/2	0 - 1/2	1/8 - 5/8	1/8 - 3/4
Taper Mount	JT-2	JT-6	JT-33	JT-3	JT-4
Body Diameter (in.)	1-15/32	1-5/8	1-25/32	2-3/16	2-7/8
Overall Length (in.)	2-3/8	2-31/32	3-1/8	3-11/16	5



DRILLING HELPFUL INFO

JET WANTS TO MAKE YOUR JOB EASIER BY PROVIDING BASIC AND HELPFUL INFORMATION ON ALL OF OUR DRILLING MACHINES AND ACCESSORIES, AS WELL DRILLING IN GENERAL.

OVERVIEW

Drilling machines or drill presses are one of the most common machines found in the machine shop. A drill press is a machine that turns and advances a rotary tool into a workpiece. The drill press is used primarily for drilling holes, but when used with the proper tooling, it can be used for a number of machining operations. The most common machining operations performed on a drill press are drilling, reaming, tapping, counterboring, countersinking, and spotfacing.

There are many different types or configurations of drilling machines, but most drilling machines will fall into four broad categories: upright sensitive, upright, radial, and special purpose.

Basically the parts of a drill press are a base, table, column, spindle and drill head. And it drills holes accurately and consecutively. This is because of the spindle's perfect alignment in proportion to the table.

COMMON DRILL TERMINOLOGY

- A** STOP & START BUTTONS
- B** SPINDLE
- C** DRILL CHUCK
- D** HAND FEED LEVER
- E** MOTOR
- F** TABLE
- G** TABLE CLAMP
- H** COLUMN
- I** BASE



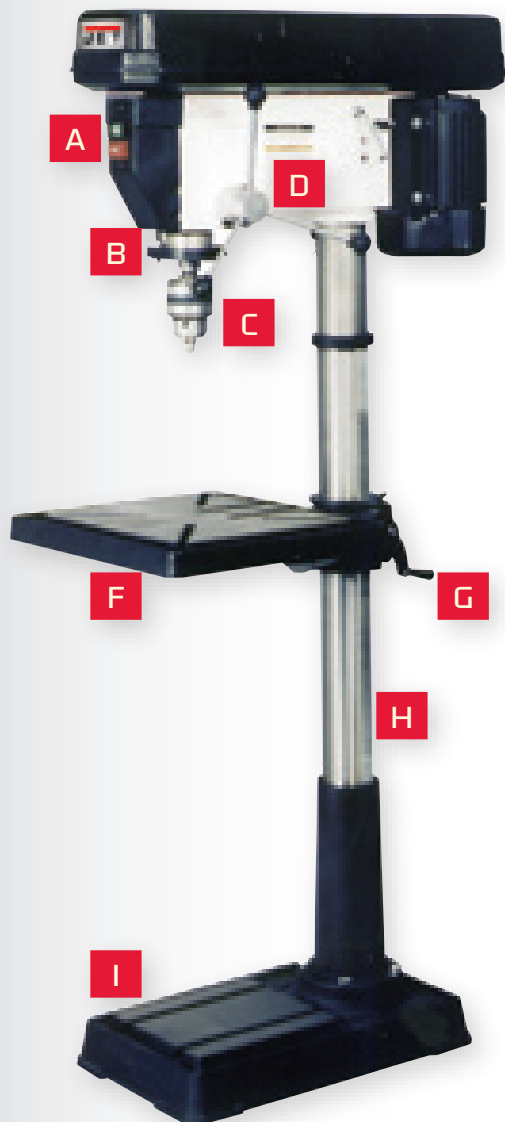

HOW TO MEASURE A DRILL PRESS

A drill press is not measured for height, but capacity. The dimensions to consider are the chuck size, the distance between the drill chuck and table and the distance from the spindle center to the support column.

Note: The measurement of twice the swing is the size of the drill press. Example: A drill press with 6" swing is a 12" Drill Press. The swing is double to show the largest circle a machine drills to center.

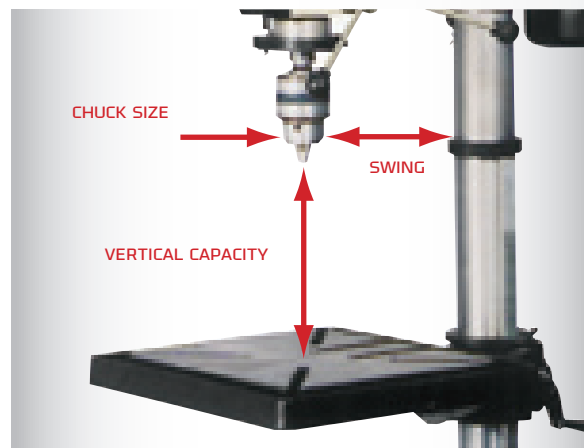



GRINDING & FINISHING

For a high-quality finish every time, the pros rely on JET grinders, sanders and finishing machines. Because your complete satisfaction is our main objective, JET Bench Grinders, Sanders and Finishing machines are built to last and exceed your expectations. Professionally-written manuals enable more efficient use, and every JET machine is backed by our industry-leading two-year warranty .



A HIGH-QUALITY FINISH EVERY TIME



CONTENTS

BELT AND DISC MACHINES	114-117
BELT GRINDERS.....	118-121
DISC GRINDERS	122-123
BENCH GRINDERS.....	124
METAL DUST COLLECTOR.....	125
FINISHING HELPFUL INFO.....	126-127

INDUSTRIAL COMBINATION BELT AND DISC FINISHING MACHINE

High-speed precision and amazing versatility. This rugged piece of equipment has a belt that operates at any angle, and conforms to curves, angles or circular finishing and grinding operations. Machinists who take great pride in their work prefer the JET Industrial Combination Belt & Disc Finishing Machine.



414551

FEATURES

- Belt operates at any angle
- Powered by a heavy-duty 1-1/2HP TEFC motor
- Fully machined, balanced disc runs vibration free
- Contour finishing, mitering, flat finishing, beveling and precision finishing
- Plain and compound miters are easily obtained by using the standard die cast aluminum miter gauge

STANDARD EQUIPMENT

- Removable upper guard for contour finishing
- Completely enclosed drums and a guarded sanding belt
- Adjustable heavy-duty cast iron removable platen
- Variable position locks, belt head adjusts vertically, horizontally and in between
- Large cast iron slotted table
- Adjustable dust collector and dust chute
- Heavy-duty one piece steel stand



REMOVABLE UPPER GUARD FOR CONTOURING



LARGE LOCKING NUT AND TABLE ANGLE SCALE

STOCK NUMBER	414551	414552	414553
Model Number	J-4200A	J-4200A-2	J-4202A
Disc Speed (RPM)	1,960	1,960	1,960
Belt Size (in./W x L)	6 x 48	6 x 48	6 x 48
Belt Speed (SFPM)	2,850	2,850	2,850
Disc Table Size (in./L x W)	12 x 16-3/8	12 x 16-3/8	12 x 16-3/8
Table Slots (in.)	3/8 x 3/4	3/8 x 3/4	3/8 x 3/4
Disc Table Tilt (deg.)	45° out and 20° in	45° out and 20° in	45° out and 20° in
Motor	1-1/2HP, 115V, 1Ph	1-1/2HP, 230V, 1Ph	1-1/2HP, 230V, 3Ph
Overall Dimensions (in./ L x W x H)	26 x 19 x 58	26 x 19 x 58	26 x 19 x 58
Net Weight (lbs.)	250	250	250

6" x 48" BELT AND 10" DISC MACHINE

This JET Combination Belt and Disc Machine offers every user a desirable combination of power, precision and versatility. Belt changes are quick and easy, and mitering applications are no problem for a superior finish to every job.



FEATURES

- Two cast iron tilting tables for mitering applications
- Quick-release tension mechanism makes belt changes quick and easy
- Enclosed base protects motor from dust and debris
- 6" x 48" Belt
- 10" Disc
- Full access to the belt when tilted in the horizontal position
- Dust collection shrouds on belt and disc
- Removable safety key switch

STANDARD EQUIPMENT

- Miter gauge
- Heavy-duty one piece steel stand



BELT TENSIONING LEVER



2" DUST CHUTE

STOCK NUMBER	414550K
Model Number	J-4210K
Disc Speed (RPM)	2,100
Belt Size (in./W x L)	6 x 48
Belt Speed (SFPM)	1,650
Disc Table Size (L x W/in.)	7-1/2 x 13
Table Slots (in.)	5/8
Disc Table Tilt (deg.)	45 out
Motor	1HP, 115V, 1Ph
Overall Dimensions (in./ L x W x H)	23 x 26 x 61
Net Weight (lbs.)	170

1" x 42" BENCH BELT AND DISC SANDER

Every shop needs a combination Sander capable of delivering premium finishes every time. The JET-J4002 is a powerful and versatile machine, performing the work of a jig saw, coping saw or hand file removing material and creating a superior finish at the same time. Deluxe miter gauge, removable platen and cast iron construction are among the features that draw pros to this JET machine.



FEATURES

- Deluxe miter gauge turns and locks for common angles 45° left and right
- Removable platen allows for sanding, grinding or finishing of outside curves or odd shaped work pieces on the belt
- Hinged idler wheel cover
- Abrasive belt unit does the work of a jig-saw, coping saw or hand file while removing material and finishing at the same time, allows the operator to get into small openings plus handle odd shapes and angles

STANDARD EQUIPMENT

- Deluxe miter gauge
- Cast iron tilting table
- Cast construction
- Heavy-duty steel base and rubber feet
- Removable platen
- Adjustable dust deflector and dust chute



HEAVY-DUTY STEEL BASE AND RUBBER FEET



REMOVABLE PLATEN

STOCK NUMBER	577003
Model Number	J-4002
Disc Speed (RPM)	1,725
Belt Size (in./W x L)	1 x 42
Belt Speed (SFPM)	3,000
Disc Table Size (in.)	4 x 10
Table Slots (in.)	5/8
Disc Table Tilt (deg.)	45 out
Motor	1/3HP, 115VAC, 1Ph
Overall Dimensions (in./ L x W x H)	21 x 22 x 14
Net Weight (lbs.)	62

2" x 42" BENCH BELT AND 8" DISC SANDER

Another JET combination Bench Belt and Disc Sander designed to deliver the superior finish. The design of this machine permits sanding, grinding and finishing of outside curves or odd-shaped pieces. Heavy-duty base, cast construction and cast iron tilting table means you are getting the very best JET has to offer.



FEATURES

- Deluxe miter gauge that turns and locks for common angles, 45° both left and right
- Allows for sanding, grinding or finishing of outside, curves or odd shaped work pieces on the belt
- Hinged idler wheel cover
- Abrasive belt unit does the work of a jig saw, coping saw or hand file while removing material and finishing at the same time, allows the operator to get into small openings, plus handle odd shapes and angles

STANDARD EQUIPMENT

- Miter gauge
- Cast iron tilting table
- Cast construction
- Heavy-duty steel base and rubber feet
- Removable platen
- Dust deflector and chute

STOCK NUMBER	577004
Model Number	J-41002
Disc Speed (RPM)	3,450
Belt Size (in./W x L)	2 x 42
Belt Speed (SFPM)	3,100
Disc Table Size (in.)	10-3/4 x 7-1/2
Disc Table Tilt (deg.)	45
Motor	3/4HP, 115V, 1Ph
Overall Dimensions (in./L x W x H)	20-1/2 x 22-3/4 x 20
Net Weight (lbs.)	60



EASY TO USE MITER GAUGE



TILT TABLE ADJUSTMENT HANDLE



BELT TENSIONING HANDLE

6" INDUSTRIAL BELT FINISHING MACHINE

This JET Industrial Belt Finishing Machine starts with a heavy-duty, one piece steel stand and miter gauge, but offers users so much more in the way of versatility for high-performance results. Variable position locks for both vertical and horizontal belt head adjustments, removable/adjustable heavy-duty cast iron platen and tilting table permit premium contour finishes, as well as plain and compound mitering. A sleek design means it fits anywhere on your shop floor.



FEATURES

- Table tilts 45° out and 20° in for all angle finishing operations
- Completely enclosed drums and a guarded sanding belt
- Variable position locks, belt head adjusts vertically, horizontally and in between
- Adjustable dust deflector for and dust chute
- Fine thread adjustment for simple and easy belt tracking
- Plain and compound miters are easily obtained by using the standard diecast aluminum miter gauge
- Will handle virtually all the finishing operations in a production line
- Adjustable heavy-duty cast iron removable platen
- Removable upper guard for contour finishing

STANDARD EQUIPMENT

- Miter gauge
- Heavy-duty one piece steel stand



REMOVABLE UPPER GUARD FOR CONTOURING

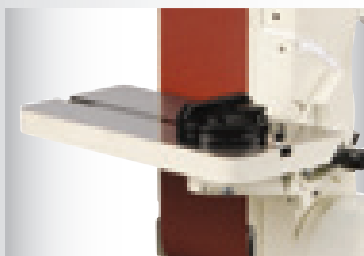

TABLE TILTS 45 DEGREES OUT AND 20 DEGREES IN FOR ANGLE FINISHES

STOCK NUMBER	414600	414601
Model Number	J-4300A	J-4301A
Belt Size (in./ W x L)	6 x 48	6 x 48
Belt Speed (SFPM)	2,850	2,850
Belt Table Size (in.)	7-3/8 x 14-3/4	7-3/8 x 14-3/4
Belt Table Tilt (deg.)	45° out and 20° in	45° out and 20° in
Platen (in./L x W)	6-1/4 x 14-3/4	6-1/4 x 14-3/4
Motor	1-1/2HP, 115/230V, 1Ph, Prewired 115V	1-1/2HP, 230V, 3Ph
Overall Dimensions (in./ L x W x H)	26 x 19 x 58	26 x 19 x 58
Net Weight (lbs.)	215	215

3" x 79" BELT GRINDER

NEW

Perhaps the thing operators notice first when putting the JET BG-379 through its paces is how safe and easy it is to use, even when grinding larger pieces along the entire length of the belt. Pivoting belt assembly and hinged top cover, advanced belt tracking, vented and fixed front wheel and the JET exclusive Spark Arrester allow broad use of this JET Belt Grinder. Power and precision you can count on; backed by the industry-leading Two Year Warranty.



FEATURES

- Pivots up and down on base for easy and safe work height adjustments
- Hinged top cover opens for access to grind large pieces using the entire length of the belt
- Advanced belt tracking with vented front wheel fixed in place for rigidity when grinding on the wheel radius
- Sturdy enclosed base
- Fully assembled for immediate use
- Locking handle for top cover
- 3" Round connector and hose clamp for ease of mounting to a metalworking dust collection system
- JET exclusive Spark Arrester to prevent sparks from flying while using the full length of the belt
- Supplied with 3 extra 80 grit Silicon Carbide Belts standard

STOCK NUMBER	414610	414615
Model Number	BG-379-1	BG-379-3
Belt Size (in. / W x L)	3 x 79	3 x 79
Belt Speed (SFPM)	6600	6600
Contact Wheel Size (in. W x dia.)	3 x 8	3 x 8
Full Grinding Plane (in. W x L)	3 x 21	3 x 21
Motor	4HP, 220V, Single Phase 60Hz	4HP, 220V, 3- Phase 60Hz
Net Weight (lbs.)	200	210

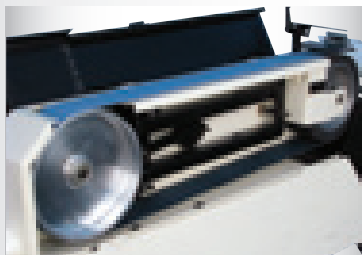

ADVANCED BELT TRACKING WITH VENTED FRONT WHEEL FIXED IN PLACE FOR RIGIDITY WHEN GRINDING ON THE WHEEL RADIUS



JET EXCLUSIVE SPARK ARRESTER TO PREVENT SPARKS FROM FLYING WHILE USING THE FULL LENGTH OF THE BELT



HINGED TOP COVER OPENS FOR ACCESS TO GRIND LARGE PIECES USING THE ENTIRE LENGTH OF THE BELT

2" x 72" SQUARE WHEEL BELT GRINDER

The JET Square Wheel Grinder is a belt grinder that uses a flat platen and idler wheels at each end to achieve a long, flat grinding surface. This innovative design permits grinding on the front wheel, which is square to the work and not crowned. The JET Square Wheel Belt Grinder, Models J-4103 and J-4126AC, grind, deburr and chamfer with equal proficiency both internal/external on parts large and small parts. Accessories allow the user to convert the Square Wheel Belt Grinder for polishing or buffing finished parts and grinding small internal radii. Accessory changeover is quick and easy, as is adjusting belt tension and tracking.

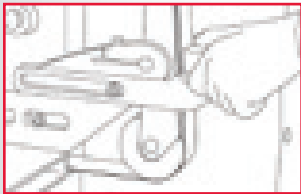

FLAT OR ANGULAR STOCK

Platen setting is the perfect angle for high speed, precision, flat and level grinding of tools, knives, plastics, and other materials. The platen allows working to very close tolerances. An adjustable work rest is standard on all models.

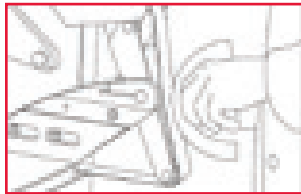

SHAPING

deal for grinding and finishing cylindrical shapes. The yoke surface conforms to the shape of the surface to produce a smooth, even finish without the danger of scarring. Excellent for tool post applications.



ROUGHING

Serrated contact wheel is used for removing heavy stock, cleaning up a weld or snagging a casting. This durable 8-inch diameter wheel is used extensively for hollow grinding and profiling knives and other culinary tools. It is standard equipment on all models.

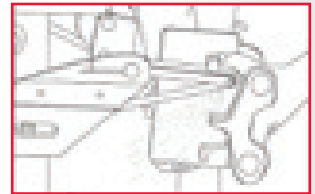

INTERNAL CONTOURING

The air-cushioned dead head allows very small radius grinding. When connected to a shop air source (80-90 psi), the belt rides on a cushion of air to decrease head and belt wear. The dead head is easy to use, and adapts to any of the available radius tips.



BELT TENSIONING ADJUSTMENT



WORK REST



UPPER COVER

577000



577001



FEATURES

- Flat & Angular Stock: Platen setting is the perfect angle for high speed, precision flat and level grinding
- Shaping: For grinding, and refinishing cylindrical shapes. Yoke surface conforms to shape of the surface to produce an even, smooth finish
- Roughing: Serrated contact wheel is used for removing heavy stock, cleaning up a weld or snagging a casting
- Contouring: Grind difficult to reach areas with the 3" x 2" or 1-1/2" x 2" diameter contact wheels
- Infinite variable speeds 1100 to 6,000 sfpm
- Latest AC Inverter variable speed technology
- Continuous speed adjustment while in operation
- Easy to view SFPM readout

STOCK NUMBER	577000	577001
Model Number	J-4103	J-4126AC
Belt Size (in./W x L)	2 x 72	2 x 72
Belt Speed (SFPM)	4,600	1,100 - 6,000
Contact Wheel Diameter (in.)	8 x 2; 3 x 2; 1-1/2 x 2	8
Contact Wheel Durometer	70	70
Motor	1HP, 115/230V, 1Ph, Prewired 115V	1HP, 115V, 1Ph, AC Inverter
Overall Dimensions (in./ L x W x H)	17 x 31 x 17	17 x 31 x 17
Net Weight (lbs.)	163	163



USA MADE BALDOR MOTOR



AC INVERTER VARIABLE SPEED TECHNOLOGY

20" DISC GRINDER

This large surface disc grinder from JET is designed to put a smooth finish or grind to remove stock on just about anything that comes through your shop. An extra large tilting table ensures user flexibility perhaps previously unimagined, and added safety features ensure your shop stays accident free. JET backs this machine with its industry-leading Two Year Warranty.



577010

FEATURES

- Extra large tilting table lowers completely below disc for use of the entire disc surface
- Tilting table capability adds flexibility of 45° forward and 30° backward on positive lock rack and gear
- Equipped with a LVP or low voltage protection ON/OFF switch which trips to the off position when the voltage drops below a predetermined safe level

STANDARD EQUIPMENT

- Direct drive motor
- Low voltage protection switch
- Rigid column and heavy-duty base
- Miter gauge
- Wrap-over guard for added safety



LOW VOLTAGE PROTECTION SWITCH
WRAP OVER GUARD FOR ADDED SAFETY



TABLE TILTS 45 DEGREES OUT AND 20 DEGREES IN FOR ANGLE FINISHES

STOCK NUMBER	577010	577011
Model Number	J-4421-2	J-4421-4
Disc Diameter (in.)	20	20
Disc Speed (RPM)	1,725	1,725
Disc Table Size (in./ L x W)	27-1/2 x 10-1/2	27-1/2 x 10-1/2
Table Slots (in.)	3/8 x 3/4	3/8 x 3/4
Disc Table Tilt (deg.)	45° out, 15° in	45° out, 15° in
Motor	3HP, 220V, 3Ph	3HP, 460V, 3Ph
Overall Dimensions (in./ L x W x H)	30 x 28 x 53	30 x 28 x 53
Net Weight (lbs.)	400	400

12" INDUSTRIAL DISC FINISHING MACHINE

Fine finishing requires a skilled hand. This JET Industrial Disc Finishing Machine enables you to put both metal and wood to the disc, with equally superior results. A fully machined, balanced disc eliminates vibration, and the defects that might otherwise occur. Achieve plain and compound mitering for unique finishes. Professionals take pride in their work, and that's why they turn to JET.



414602

FEATURES

- Optimum speed of 1,960 RPM, which is ideal for both metal and wood finishing
- Fully machined, balanced disc runs vibration free
- Easy to read scale shows exact degree of table tilt
- Plain and compound miters are easily obtained by using the standard die-cast aluminum miter gauge

STANDARD EQUIPMENT

- Miter gauge
- Heavy-duty one piece steel stand



LARGE CAST IRON SLOTTED TABLE



12" 60 GRIT DISC INCLUDED

STOCK NUMBER	414602	414603
Model Number	J-4400A	J-4401A
Disc Diameter (in.)	12	12
Disc Speed (RPM)	1,960	1,960
Disc Table Size (in./ L x W)	12 x 16-3/8	12 x 16-3/8
Table Slots (in.)	3/8 x 3/4	3/8 x 3/4
Disc Table Tilt (deg.)	45° out and 20° in	45° out and 20° in
Motor	1-1/2HP, 115/230V, 1Ph, Prewired 115V	1-1/2HP, 230/460V, 3Ph, Prewired 230V
Overall Dimensions (in./ L x W x H)	16 x 19 x 43	16 x 19 x 43
Net Weight (lbs.)	175	175

SHOP BENCH GRINDER

For shops that may be short on space, a cast iron JET Bench Grinder delivers work power and pristine finishes. Built to withstand the high-volume demands of even the busiest shops, this high-quality machine grinds, sharpens and smooths with equal precision and flawless results.



577101

FEATURES

- UL listed
- Totally enclosed pre-lubricated ball bearings
- Heavy-duty guarded toggle switch on 8" and 10"
- Rubber mounts prevent movement

STANDARD EQUIPMENT

- Cast iron wheel guards and dust vents
- One-piece quick adjusting spark guards
- Large eye shields with quick adjustment
- Adjustable tool rests
- Fine and coarse vitrified grinding wheels included

STOCK NUMBER	577101	577102	577103
Model Number	JBG-6A	JBG-8A	JBG-10A
Shaft Diameter (in.)	1/2	5/8	1
Wheel Diameter (dia. x W/in.)	6 x 3/4	8 x 1	10 x 1
Wheel Speed (RPM)	3,450	3,450	1,725
Wheel Grits	36/60	36/60	24/46
Motor	1/2HP, 115V, 1Ph	1HP, 115V, 1Ph	1-1/2HP, 115V, 1Ph
Overall Dimensions (in./ L x W x H)	17 x 10 x 9	19 x 12 x 11	25 x 16 x 15
Net Weight (lbs.)	38	60	110



LARGE EYE SHIELDS



CAST IRON GUARDS AND DUST CHUTES



ADJUSTABLE CAST IRON TOOL RESTS



PEDESTAL STAND FOR BENCH GRINDERS

FEATURES

- Heavy-duty cast iron construction provides strength and durability
- Wide stance base gives you a stable grinder workstation
- Coolant tank and tool tray are on an adjustable platform for your convenience
- Compatible with all JET Bench Grinders

STOCK NUMBER	577172
Model Number	JPS-2A
Mounting Surface (in./ L x W)	11 x 10
Overall Dimensions (in./ L x W x H)	31 x 21 x 5
Net Weight (lbs.)	52



METAL DUST COLLECTOR

JET'S new Metal Dust Collector is great for collecting abrasive dust from belt & disc finishing and grinding machines. Chips and dust collect into a metal drawer that is easy to clean, and no cloth bag eliminates the risk of a fire! Two 4" chutes allows you to attached two different machines, and portable casters allows for use throughout your shop. Enhance the health and safety levels in your shop with JET innovation.



FEATURES

- Non-sparking aluminum housing and fan blade
- Easy to empty clean-out drawer
- Easy to change air filter
- Quiet, effective dust collection method
- Portable on 4 casters and 2 handles for ease of movement
- 4" to 3" Hose adapter include



ON/OFF WITH SAFETY KEY



DUST CHUTE



DUST DRAWER

STOCK NUMBER	414700
Model Number	JDC-500
Maximum CFM	490
Maximum Hose Velocity (SFPM)	5610
Filter (WxLxD/in.)	19 x 9-1/2 x 1-3/4
Filter Efficiency:	99% @5micron
DBA @ 5'	75
Hose Size (WxL/in.)	4
Overall Dimensions	30-1/2 x 31-1/2 x 31-1/2
Motor	1/2HP
Net Weight (lbs.)	157

OPTIONAL EQUIPMENT	STOCK NUMBER
3" Heat Resistance Hose to 130 Degrees	414715
3" Heat Resistance Hose to 180 degrees	414720
4" Heat Resistance Hose to 130 Degrees	414705
4" Heat Resistance Hose to 180 Degrees	414710
Pair of Replacement Filters	414705

FINISHING HELPFUL INFO

EVERY JET MACHINE IS DESIGNED WITH THE SOLE INTENT OF MAKING YOUR JOB EASIER. HERE IS SOME BASIC AND HELPFUL INFORMATION ON ALL OUR FINISHING MACHINES TO ENHANCE THE USER EXPERIENCE.



GRINDING/FINISHING MACHINES APPLICATIONS

Belt grinding is a versatile process suitable for all kinds of different applications. There are three different applications of the belt grinding technology:

- 1 Finishing: surface roughness, removal of micro burrs, cosmetic finishes, polishing
- 2 Deburring: radiusing, burr removal, edge breaking
- 3 Stock removal: high stock removal, cleaning (e.g. of corrosion), eliminating mill or tool marks, dimensioning

CHANGING VARIABLES

There are several objectives possible for grinding with coated abrasives. Among them are the right application (e.g. finish or stock removal), time saving and efficiency of the abrasive tool. To achieve the above objectives, it is essential to look in more detail to the variables, which affect them. These include the work material properties, the grit and abrasive type of the grinding belt, belt speed, belt sequences, contact wheel hardness and diameter, serration, type of lubricant (or dry) and grinding pressure. Changing these variables will affect the performances of the belt grinding process.

TYPES OF GRINDING/ FINISHING MACHINES

Jet offers over 28 different finishing machines in different sizes, styles and many different voltages but easily breaks down to 4 different types. Refer to category summary below.

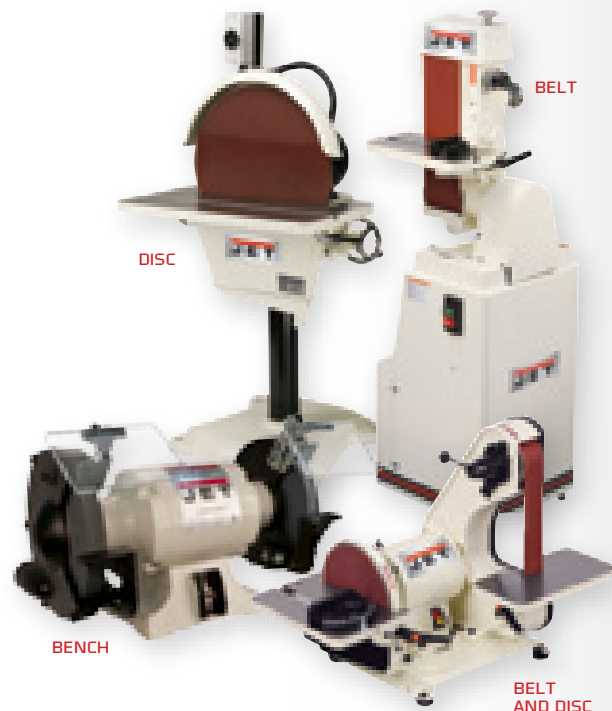



COMMON TERMINOLOGY OF GRINDING AND FINISHING MACHINES

- A** ABRASIVE BELT
- B** TOP COVER LOCK KNOB
- C** BELT ADJUSTMENT KNOB
- D** VARIABLE POSITION LOCKS
- E** ABRASIVE DISC
- F** MITER GAUGE
- G** CAST IRON TILTING TABLES
- H** TABLE LOCKING KNOB
- I** ON/OFF SWITCH
- J** HEAVY-DUTY ONE PIECE METAL STAND

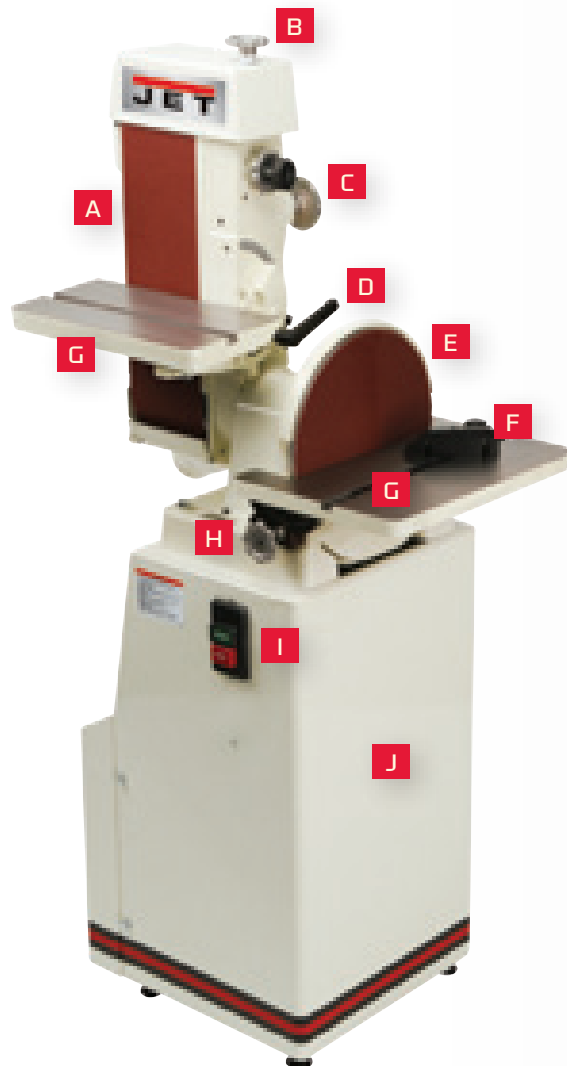



FORMING

Machine professionals who demand precision, accuracy and reliability from the equipment in their shop look to JET Metalforming equipment when adding to or upgrading their operation. High-quality JET brakes, shears, rolls, english wheel, planishing hammer, presses and notchers allow you to expand your operation and offer customers more. Professional manuals ensure quick start up and efficient operation, and JET backs all its machines with an industry-leading two-year warranty.

SHEARING, BENDING & FORMING: WHEN METALWORKING BECOMES AN ART FORM

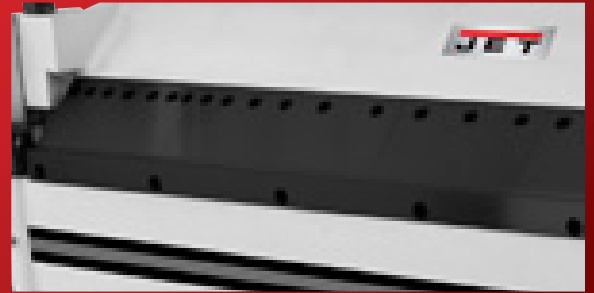

CONTENTS

SHEARS.....	130-133
BRAKES.....	134-137
SLIP ROLLS.....	138-139
ROTARY MACHINE/ NOTCHER	140
PLANISHING HAMMER	141
ENGLISH WHEEL.....	142
PRESSES.....	143-144
PIPE BENDER.....	145
FORMING HELPFUL INFO.....	146-147

52" PNEUMATIC SHEAR

The JET PS-1652T delivers the strength and accuracy your shop demands in a rugged, cast-iron grade frame. Capable of making the big cuts, and versatile enough to handle just about any job you need completed. The pneumatic control system ensures smooth operation and smooth cuts along the precision-aligned bed and beam.



FEATURES

- High-quality cast-iron grade frame to eliminate deflection across the blade-span and blade framework
- Low cutting angle to cut narrow strips without twisting
- Precise bed and beam alignment assures working accuracy
- Adjustable working bed for correct setup according to the blade clearance
- 16 gauge maximum cutting capacity for mild-steel
- 12-14 gauge maximum cutting capacity for aluminum and copper alloys



PNEUMATIC CONTROLS NOW MAKES SHEARING A ONE MAN JOB



EASY TO USE FOOT CONTROL WITH E-STOP RIGHT IN THE OPERATORS REACH

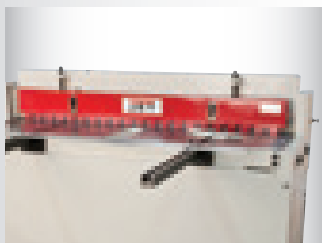

PRECISION BED AND BEAM ALIGNMENT ASSURES WORKING ACCURACY

STOCK NUMBER	756203
Model Number	PS-1652T
Max. Soft Alloy Capacity (Gauge)	12 - 14
Mild Steel Capacity (Gauge)	16
Shearing Length Capacity (in.)	52
Back and Front Gauge Capacity (in.)	28-1/2 and 28
Strokes per Minute (Full Length)	40
Air Consumption per Stroke (CFM)	1.3
Air Consumption (CFM)	25.3
Overall Dimensions (in./ L x W x H)	60 x 24 x 43
Net Weight (lbs.)	1,048

FOOT SHEARS

JET Foot Shears with high quality, hardened and tempered stainless steel blades are ideal for precision shearing of mild steel up to 16 gauge. An adjustable hold down clamp keeps materials secure during operation to prevent errors, and compound leverage allows the user to perform work within the machine's rated capacity with ease.



FEATURES

- Ideal for precision shearing of mild steel up to 16 gauge
- Two-way blade configuration provides twice the cutting life
- Upper blade is two-way; bottom blade is one-way
- 2° angle cutting edge; 1° face relief



SCALE GUIDES MARKED FOR PRECISE CUTTING.



CAPABLE OF SHEARING SHEET STEEL, BARS PLUS MANY NON-METALLIC MATERIALS

STOCK NUMBER	752636	752652
Model Number	FS-1636H	FS-1652H
Mild Steel Capacity (Gauge)	16	16
Shearing Length Capacity (in.)	36	52
Back Gauge Capacity (in.)	30	30
Front Gauge Capacity (in.)	28	28
Overall Dimensions (in./ L x W x H)	46 x 74 x 42	63 x 74 x 42
Net Weight (lbs.)	816	1,014

SLITTING SHEAR WITH HANDLE

JET Slitting Shears deliver precision cuts and true edges to a wide variety of materials including steel, aluminum, brass, copper, lead, plastic and zinc. The two-way upper blade configuration provides double the cutting life. JET Portable Slitting Shears, capable of shearing sheet steel, steel bars and rods, and many non-metallic materials, allow you to take JET reliability and power to the worksite.



FEATURES

- Capable of shearing sheet steel, steel bars and rods plus many non-metallic materials
- Replaceable high quality stainless steel blades are hardened and tempered for maximum service life
- An adjustable hold down clamp aids in securing material
- Compound leverage allows the operator to easily perform work within shears' rated capacity
- Includes 35-1/2" handle



GUIDE FOR CUTTING RODS

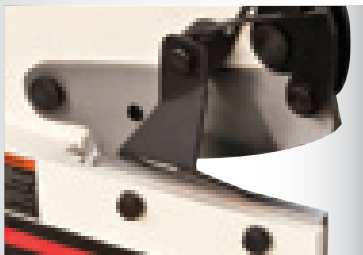

REPLACEABLE STAINLESS STEEL BLADES ARE HARDENED AND TEMPERED

STOCK NUMBER	755108K	755112K
Model Number	SS-8T	SS-12T
Sheet Capacity (Mild Steel/in.)	3/16	1/8
Flat Capacity (Mild Steel/in.)	2-3/4 x 1/4	2-3/8 x 5/32
Round Capacity (Mild Steel/in.)	1/2	1/2
Cutting Blade Length (in.)	8	11-3/4
Overall Dimensions (in. / L x W x H)	17 x 7 x 17	22 x 7 x 18
Net Weight (lbs.)	55	75

COMBINATION SHEAR, BRAKE AND ROLL

NEW

JET innovation allows machine shop professionals the ability to perform several vital tasks with a single compact machine. The Combination Shear, Brake and Roll handles the jobs of three separate machines, adding tremendous versatility to your metal forming operation, without crowding the shop floor. This high-quality triple threat is backed by the JET industry-leading Two Year Warranty.



FEATURES

- Combination shear, brake and roll in one compact machine
- Right or left hand operation
- Shear can be used for mild steel, aluminum, brass, copper, lead, plastic and zinc
- Brake is equipped with easily removable fingers that permit angle, channel, box and other complex bending operations
- Slip rolls are precision turned and ground with wire grooves

STANDARD EQUIPMENT

- Set of male dies
- One set of female dies
- Dual edge shear blade
- Spring-loaded work hold down
- Back gauge



BRAKE



ROLL



SHEAR

STOCK NUMBER	756031	756041
Model Number	SBR-30M	SBR-40M
Mild Steel Capacity (Gauge)	20	20
Shearing Capacity (Gauge)	20	20
Bending Capacity (Gauge)	20	20
Rolling Capacity (Gauge)	20	20
Size of Slip Roll (in./ L x Dia.)	30 x 1-1/2	40 x 1-5/8
Width of Upper Dies (in.)	1, 2, 3, 6, 8, 10	1, 1-1/2, 2, 2-1/2, 4, 7, 10, 12
Upper Die Height (in.)	4-11/16	4
Min. Forming Radius (in.)	3/4	1
Wire Grooves (in.)	1/8, 3/16, 9/32	3/16, 9/32, 3/8
Base Dimensions (in./ L x W x H)	14-1/2 x 32-3/8	16-1/2 x 43
Overall Dimensions (in./ L x W x H)	40 x 16 x 24	56 x 23 x 30
Net Weight (lbs.)	290	575



754030

OPTIONAL EQUIPMENT	STOCK NUMBER
Floor Stand for SBR-30M	754030
Floor stand for SBR-40M	754040

FLOOR BOX AND PAN BRAKE WITH FOOT CLAMP

NEW

Precision and durability with innovative ergonomic features ensures ongoing accuracy and operation, without user fatigue.



752125



FEATURES

- Wide assortment of finger widths allow greater versatility in the shop
- Black ceramic coated fingers prevent rust and ensure longer finger life
- All body sections are welded steel plate with heavy truss rods and braces designed to give greater strength and durability
- Stop rod for repeatable bending
- Material clamping is foot operated to save strain on back and arms
- Hydraulic spring to assist in raising the clamping handle

STANDARD EQUIPMENT

- Total of 16 assorted size section fingers



BLACK CERAMIC COATED FINGERS PREVENT RUST AND ENSURE LONGER FINGER LIFE



HYDRAULIC SPRING TO ASSIST IN RAISING THE CLAMPING HANDLE



LARGE EASY TO USE FOOT CLAMP WHICH ALLOWS THE OPERATOR HANDS FREE CLAMPING

STOCK NUMBER	752125	752127
Model Number	PBF-1240	PBF-1450
Mild Steel Capacity (Gauge)	12	14
Bending Length Capacity (in.)	40	50
Max. Clamping Bar Lift (foot operated)	1-7/8	1-7/8
Maximum Box Depth (in.)	4	4
1Finger @ Width (in.)	1-1/8, 1-3/8, 1-1/2, 1-3/4, 2, 3, 4, 6, 7-3/4, 10-5/8	1-1/8, 1-3/8, 1-1/2, 1-3/4, 2, 3, 4, 6, 7-3/4, 10, 10-5/8
Finger Nose Angle (degree)	42	42
Nose Radius (in.)	1/32	1/32
Overall Dimensions (in. LxWxH)	58 x 25 x 50	67 x 28 x 50
Net Weight (lbs.)	705	900

FLOOR MODEL BOX AND PAN BRAKES

Box and Pan Brakes from JET are perfect for the larger, high-volume shop that requires versatility yet demands rugged durability and bending precision.



754100

FEATURES

- Wide assortment of finger widths allow greater versatility in the shop
- All body sections are welded steel plate with heavy truss rods and braces designed to give greater strength and durability
- Both the bed and apron are bored in line to assure the utmost accuracy



COUNTER WEIGHTS CAN BE MOVED UP OR DOWN TO PROVIDE MORE OR LESS LEVERAGE

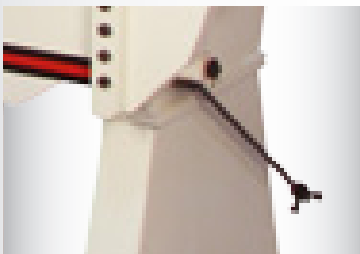

TO MAKE REPEAT BENDS ARE EASY WITH A QUICK TURN OF THE STOP COLLAR ON THE STOP ROD

STOCK NUMBER	754100	752102
Model Number	BP-1248H	BP-1696H
Mild Steel Capacity (Gauge)	12	16
Bending Length Capacity (in.)	48	96
Maximum Lift of Beam (in.)	1-1/2	2-1/4
Maximum Box Depth (in.)	4	4
Beam Adjustment (in./front to rear)	7/8	1
Number and Width of Fingers (in.)	5@3, 2@4, 5@5	5@3, 6@4, 9@5, 2@6
Finger Nose Angle (deg.)	45	45
Nose Radius (in.)	1/32	1/32
Overall Dimensions (in./ L x W x H)	70 x 34 x 52	142 x 32 x 61
Net Weight (lbs.)	1,477	1,985

BENCH MODEL BOX AND PAN BRAKES

Operates like your standard brake, but with greater versatility and wide range of applications. Easy-to-move sectioned finger enhance user capability to perform custom forming.

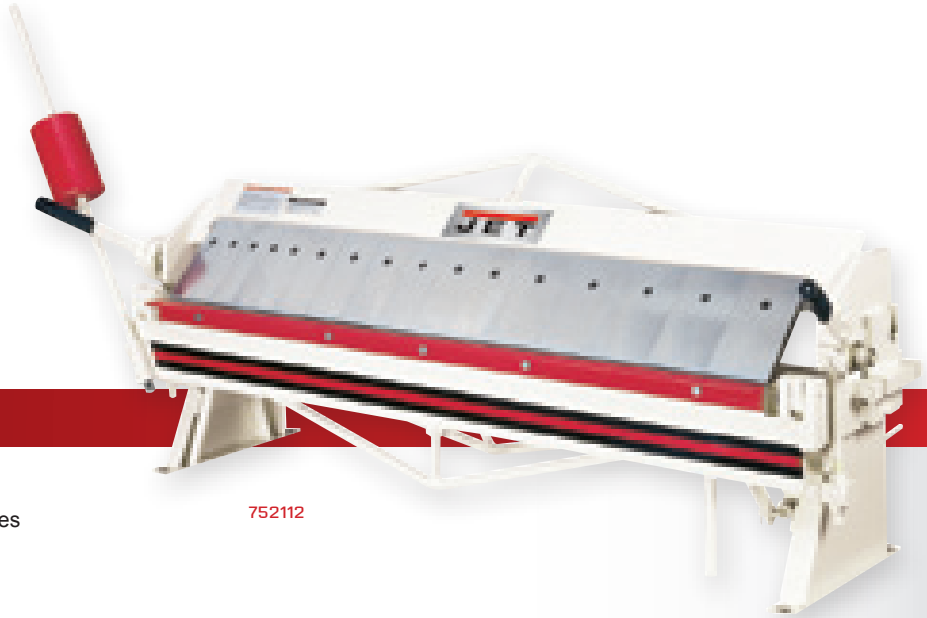

752112

FEATURES

- Incorporates all the features of our standard brakes but with greater range of applications
- With fingers installed it can be used as a full-length nose bar, turning the machine into a straight bending brake
- Sectioned fingers are easily removed for box bending and special forming operations

STANDARD EQUIPMENT

- Total of 16 assorted size section fingers

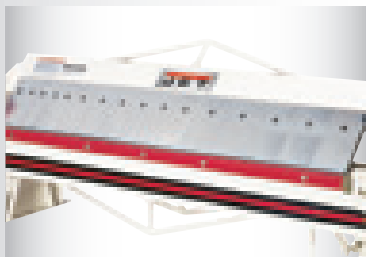

16 ASSORTED SIZE SECTION FINGERS

STOCK NUMBER	752116	752122
Model Number	BP-1648H	BP-2248H
Mild Steel Capacity (Gauge)	16	22
Bending Length Capacity (in.)	48	48
Maximum Lift of Beam (in.)	1-1/4	7/8
Maximum Box Depth (in.)	4	3
Beam Adjustment (in./front to rear)	5/8	1/8
Number and Width of Fingers (in.)	5@2, 6@3, 5@4	5@2, 6@3, 5@4
Finger Nose Angle (deg.)	45	45
Nose Radius (in.)	1/32	1/32
Overall Dimensions (in./ L x W x H)	75 x 19 x 34	61 x 31 x 28
Net Weight (lbs.)	430	258

BENCH AND FLOOR MODEL HAND BRAKES

To accommodate space restraints in your shop, as well as forming and shaping needs of your operation JET Bench and Floor Model Hand Brakes, Bench Model Box and Pan Brakes, and Floor Model Box and Pan Brakes are designed to deliver superior accuracy and durability. Finger width assortments and removable finger sections enhance overall productivity in your facility. JET Brakes are built rugged to provide superior satisfaction with every bend you make.



752002



756222

BENCH MODEL FEATURES

- Suitable for many types of metal forming operations
- All body sections are welded steel plate
- Heavy truss rods and braces are designed to give superior strength
- Precise bed and beam alignment assures working accuracy

FLOOR MODEL FEATURES

- Simplicity of design, improved truss rod construction and a minimum number of moving parts make the JET hand brake easy to operate
- All body sections are welded steel plate with heavy truss rods and braces designed to give greater strength and durability
- Both the bed and apron are bored in line to assure the utmost in accuracy



OPTIONAL EQUIPMENT	STOCK NUMBER
Floor Stand for HB-2248H & HB-1648H	754200

STOCK NUMBER (BENCH)	756216	756222
Model Number	HB-1648H	HB-2248H
Mild Steel Capacity (Gauge)	16	22
Maximum Lift of Beam (in.)	1-1/4	7/8
Bending Length Capacity (in.)	48	48
Beam Adjustment (in./front to rear)	5/8	1/8
Overall Dimensions (in./ L x W x H)	61 x 21 x 28	61 x 21 x 26
Net Weight (lbs.)	342	190

STOCK NUMBER (FLOOR)	752002
Model Number	HB-1697H
Mild Steel Capacity (Gauge)	16
Maximum Lift of Beam (in.)	2-1/4
Bending Length Capacity (in.)	97
Beam Adjustment (in./front to rear)	1
Overall Dimensions (in./ L x W x H)	120 x 31 x 57
Net Weight (lbs.)	2,290

50" ELECTRICAL POWER SLIP ROLL

Rugged frame and base ensure that hardened polished, high-carbon steel rolls on the JET Electrical Power Slip Roll deliver smooth, even results. All electrical and rotating parts are designed to enhance operator safety and comfort during use. Easy setup and operation, this is a must-have for any HVAC or fabrication shop.



752116

FEATURES

- Valuable machine tool for sheet metal forming in HVAC and FAB shops
- Three-roll machine with two driven rolls.
- Rolls are made of hardened polished high-carbon steel
- Heavy-duty frame and base insure precise sheet metal rolling
- Easy setup and operation
- Forming roll has attached position scale for equal pressure adjustment
- Weight and rigidity; scale and precision; strength and simplicity define exceptional comfort and ease of operation.
- Convenient foot-control assembly with emergency-button
- All electrical and rotating parts are designed for safety and comfortable operation during machine use.

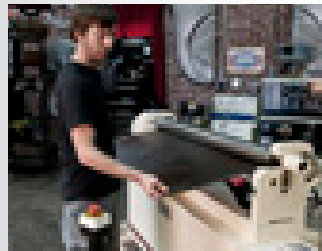

VALUABLE TOOL FOR HVAC AND FAB SHOPS



EASY TO USE FORWARD AND REVERSE FOOT PEDAL WITH E-STOP



SAFETY BAR, WHEN PUSHED WILL SHUT DOWN THE MACHINE.

STOCK NUMBER	752116	752122
Model Number	BP-1648H	BP-2248H
Mild Steel Capacity (Gauge)	16	22
Bending Length Capacity (in.)	48	48
Maximum Lift of Beam (in.)	1-1/4	7/8
Maximum Box Depth (in.)	4	3
Beam Adjustment (in./front to rear)	5/8	1/8
Number and Width of Fingers (in.)	5@2, 6@3, 5@4	5@2, 6@3, 5@4
Finger Nose Angle (deg.)	45	45
Nose Radius (in.)	1/32	1/32
Overall Dimensions (in./ L x W x H)	75 x 19 x 34	61 x 31 x 28
Net Weight (lbs.)	430	258

SLIP ROLLS

JET manual slip rolls have a forming width of 24", 36" & 50" with a capacity of 20, 22 & 16 gauge mild steel. These machines have two driven rolls of precision turned, ground and polished carbon steel. They are the perfect sheet metal forming machines to have in any general fabrication, school, racing or HVAC shop. The highly rigid construction frame ensures precision roll bending for decades of production. This sheet metal roller comes standard with three wire or rod grooves.



756020

FEATURES

- Suitable for many industrial, educational and vocational shop uses
- Precision turned carbon steel rolls that are ground and polished
- Large roll adjusting screws facilitate lifting
- upper roll for easy material removal

STANDARD EQUIPMENT

- Wire grooves are standard on SR-2024M,
- SR-2236M and SR-1650M

FLOOR STANDS FOR BENCH MODEL METALFORMING MACHINES

- We offer stands that fit our bench model hand brakes, box & pan brakes, slip rolls and combination shear, brake and rolls.



754200

STOCK NUMBER	756020	756026	756050
Model Number	SR-2024M	SR-2236M	SR-1650M
Mild Steel Capacity (Gauge/in.)	20	22	16
Max. Forming Length (in.)	24	36	50
Number and Diameter of Rolls	3 and 2	3 and 2	3 and 3
Min. Forming Radius (in.)	1	1	2
Wire Grooves (in.)	3/16, 1/4, 5/16	3/16, 1/4, 5/16	1/4, 5/16, 3/8
Overall Dimensions (in./ L x W x H)	50 x 14 x 14	62 x 14 x 14	67 x 16 x 20
Net Weight (lbs.)	216	256	565

STOCK NUMBER	754200	754024	754030	754036	754040	754051
Model Number	S-48N	SRS-24N	SRS-30N	SRS-36N	SRS-40N	SRS-50N
Fits	BP-2248H BP-1648H HB-2248H HB-1648H	SR-2024M	SBR-30M	SR-2236M	SBR-40M	SR-1650M
Overall Dimensions (in./ L x W x H)	56-1/2 x 18-1/4 x 28	30 x 14 x 28	40 x 16 x 24	42 x 14 x 28	49 x 21 x 30	68 x 22 x 30
Net Weight (lbs.)	85	35	45	51	82	70

ROTARY MACHINE

The JET Rotary Machine features a long throat that enables use for a variety of needs. Burring, edging, elbowing, flanging, flattening and turning all handled with ease and accuracy.

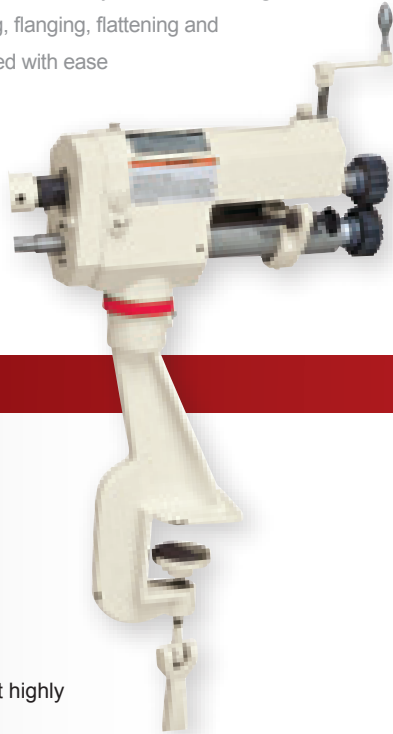

FEATURES

- Long throat makes unit highly versatile
- Performs burring, edging, elbowing, flanging, flattening and turning
- Adjustable roll pressure by means of top mounted hand crank
- Can be used in both forward and reverse
- Operation is smooth, fast and precise
- Table mount with clamp is standard
- Six interchangeable rolls with 27/32" I.D.

STOCK NO.	756022
Model Number	RM-22T
Distance Between Shaft Centers (in.)	2
Frame Throat Depth (in.)	7
Overall Dimensions (in./ L x W x H)	18 x 8 x 16
Cutting Capacity (Gauge)	22
Net Weight (lbs.)	64



SIX INTERCHANGEABLE ROLLS FOR BEADING, CLOSING, TURNING, JOGGING, CRIMPING AND FLANGING

HAND NOTCHER

JET's high quality cast iron sheet metal Notcher is ideal for any garage or sheet metal shop. It's compact design makes it perfect for on-site use. The cutting angle is fixed at ninety degrees and can notch up to 6" x 6" in one manual stroke.



FEATURES

- Made of cast iron
- Capable of notching virtually any shearable material
- Can notch angles of more than 90° through a two-step process
- Easy-to-read front gauges
- Heavy-duty cutting blade

STOCK NO.	756016
Model Number	HN-16T
Cutting Capacity (Gauge)	16
Piercing Capacity (Gauge)	18
Maximum Notch (in.)	6 x 6
Stroke (in.)	3/4
Overall Dimensions (in./ L x W x H)	24 x 21 x 26
Net Weight (lbs.)	165

OPTIONAL EQUIPMENT	STOCK NO.
Stand	754017

24" PROFESSIONAL PLANISHING HAMMER

JET's 24" Planishing Hammer has a quick change set up on the upper dies and a deep throat that works to the middle of most panels. The head with 3-speed regulator is capable of 4,400 – 4,800 / 3,200 – 3,500 / 1,800 – 2,000 blows-per-minute (BPM). Easy-to-reach, adjustable flow control valve allows the user to deliver the proper BPM needed for any job. Operates on standard shop air.



FEATURES

- Smooths beads and forms mild steel sheet metal up to 16 gauge
- Smooths beads and forms aluminum and copper up to 1/8" thick
- Machine is supplied with an upper and anvil die set
- 3-Position airflow regulates speed of pneumatic hammer
- Machine controlled with 110V foot control
- 2-Die Set Brackets
- Quick change of upper dies

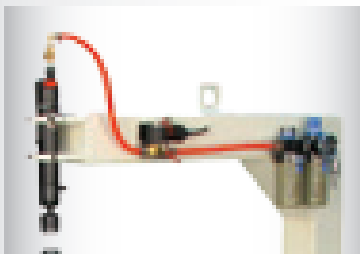

EASY TO REACH ADJUSTABLE FLOW VALVE ALLOWS THE USER TO DELIVER THE PROPER BPM NEEDED FOR ANY JOB



FRONT LEGS WITH STABILIZER BAR AND 2 BACK LEGS MAKES IT EXTRA STURDY

STOCK NUMBER	756121
Model Number	PH-24T
Frame Tube Size (in.)	4 x 4
Throat (in.)	24
Head Opening (in.)	2-1/2
Maximum Pressure (psi)	90
Air Consumption (CFM)	8.8
3-Speed Regulator (blows per min.)	1,800 - 2,000
Noise Level (dB)	92.26 - 104.3
Overall Dimensions (in./L x W x H)	34 x 30 x 61
Net Weight (lbs.)	220
Beam Adjustment (in./front to rear)	1/8
Overall Dimensions (in./ L x W x H)	61 x 31 x 28
Net Weight (lbs.)	258

45" PROFESSIONAL ENGLISH WHEEL

JET's highly versatile and highly effective metalforming and shaping machines are designed to form compound curves in sheet metal for the restoration of collectible cars, motorcycles, and airplanes. This English Wheel has an upper rolling wheel and comes standard with 4 rolling wheels and 10 lower anvil wheels with different crowns to create different radiuses.



FEATURES

- Rolls beads and forms mild steel sheet metal up to 16 gauge
- Rolls beads and forms aluminum and copper up to 1/8" thick
- Machine supplied with 10 anvils and 4 rolling wheels
- Three sets of popular fender groove shaping wheels
- Screw lift assembly designed for comfort and precise pressure setup
- Quick cam handle releases the work piece
- Both wheels swivel 90°
- Quick wheel change without using any tooling
- Wheels supplied with sealed bearings for smooth operation
- Heavy-duty frame
- Storage brackets for rolling and anvil wheels
- Throat 45"
- Rolling wheels 6" diameter



ALL WHEELS & ANVILS ARE POLISHED

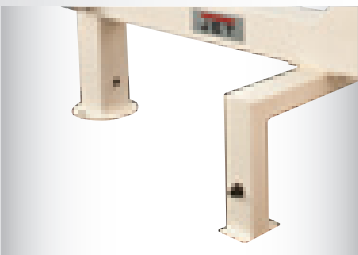

RETRACTABLE CASTERS ON ALL LEGS MAKE IT EASY TO MOVE AROUND THE SHOP

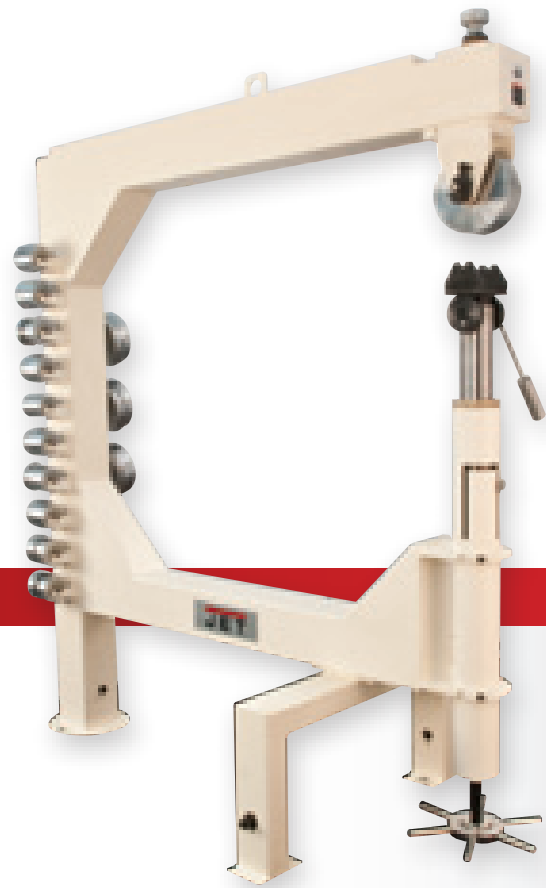

STOCK NUMBER	756151
Model Number	WH-45T
Frame Tube Sizes (in.)	4 x 4
Throat (in.)	45
Head Opening (in.)	6
Head and Anvil Sit Swivel (deg.)	90
Rolling Wheels Diameter (in.)	6
Overall Dimensions (in./ L x W x H)	64 x 31 x 58
Net Weight (lbs.)	458

ARBOR PRESS

Every JET arbor press is made of a heavy ductile iron casting that offers incredible strength and rigidity to the overall framework. The base, ram housing, framework and 4 position bottom plate are precision machined for unquestioned accuracy.



752125

FEATURES

- For all production and assembly applications
- Precision cut steel rams and pinions for accurate operation
- Tables and slotted table-plates are flat and parallel to provide accurate support



ANVIL INCLUDED WITH EVERY JET ARBOR PRESS

STOCK NUMBER	333605	333610	333620	333630	333650	754051
Model Number	AP0-M	AP1-M	AP2-M	AP3-M	AP5-M	SRS-50N
Diameter of Work (in.)	6-5/8	8	11-3/8	10-3/4	17	SR-1650M
Capacity Over Table (in.)	4-3/4	5-7/8	9	12-1/2	18-1/6	68 x 22 x 30
Size of Ram Face (in.)	3/4 x 7-7/8	1 x 9-1/8	1-1/4 x 13	1-1/2 x 18	2 x 27-1/2	70
Approx. Pressure (tons)	1/2	1	2	3	5	70
Ram Bore (in.)	3/8	3/8	1/2	1/2	1/2	70
Height (in.)	10.9	12	16-1/4	21-1/2	35	70
Base Size (in.)	4 x 9-1/2	5 x 10-3/4	6-3/8 x 17	8-1/2 x 18	9-7/8 x 26	70
Net Weight (lbs.)	19	27	68	108	262	70

HYDRAULIC SHOP PRESSES

JET's Hydraulic Shop Press line consists of a 5, 15 and 35 ton hydraulically powered H frame press. Each machine is built using heavy steel plate that is electro welded together, and comes standard with industrial grade hydraulics. These machines are for the serious fabrication and machine shop owner who demands only the best quality from his operation.

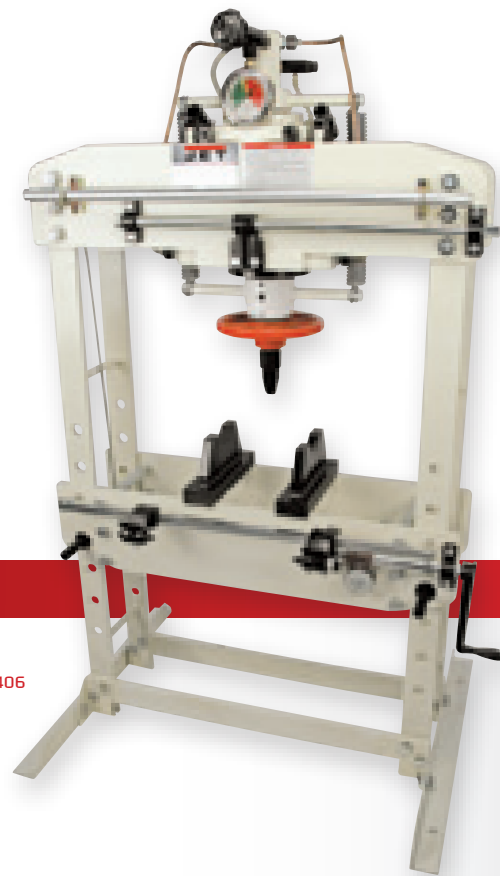

331406

FEATURES

- For pressing, bending and straightening operations
- Easy-to-use, hand-operated with pressure gauge for direct pressure readings
- Tables raise and lower easily with use of hand crank on the 15-, 35-ton models
- Side frames are open for inserting long material
- Fast setup ram extension screw
- Ram moves laterally for added versatility (15-ton and 35-ton models)

STANDARD EQUIPMENT

- Two bed plates and pump handles
- Straightness testing support uses centers or v-blocks on the 15-, 35-ton models



EASY TO USE LARGE HAND WHEEL

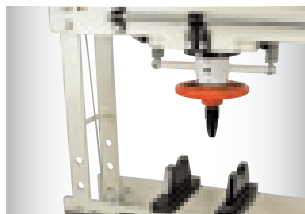

SIDE FRAME IS OPEN FOR INSERTING LONG MATERIAL

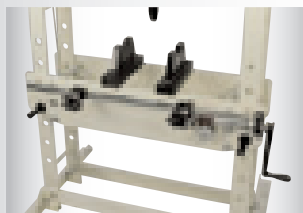

TABLE RAISES AND LOWERS EASILY WITH HAND CRANK ON THE 15 & 35 TON MODELS

STOCK NUMBER	331406	331416	331431
Model Number	HP-5A	HP-15A	HP-35A
Capacity (tons)	5	15	35
Ram Diameter (in.)	1-3/4	2-1/2	3
Piston Stroke (in.)	4	4-1/2	4-3/4
Screw Stroke (in.)	3	3-1/8	4
Work Table Size (in.)	19 x 5-1/2	24-3/4 x 7-1/2	31 x 10-3/8
Lateral Movement (in.)	N/A	10-3/16	15
Vertical Table Travel (in.)	15-3/4	22-3/16	23-5/8
Overall Dimensions (in./ L x W x H)	24 x 26 x 52	34 x 30 x 66	43 x 34 x 69
Net Weight (lbs.)	192	435	783

MANUAL PIPE BENDERS

JET Manual Hydraulic Pipe Benders are the bender of choice among fabricators who need a hydraulically powered, easy to use bending machine for general fabrication work, whether on the job or at home. Since no external power is needed to operate, it is ideal for use on the job site.



331900

FEATURES

- For all production and assembly applications
- Precision cut steel rams and pinions for accurate operation
- Tables and slotted table-plates are flat and parallel to provide accurate support



UPPER AND LOWER HEAVY DUTY WING PLATE



PUMP THE EASY TO USE HANDLE TO BEND PIPE

STOCK NUMBER	331900	331910
Model Number	JHPB-20	JHPB-30
Pipe Size Capacity (in.)	1/2-2	1/2-3
Max. Pipe Wall Thickness (in.)	1/5	6/25
Maximum Load (tons)	9	20
Piston Stroke (in.)	10-1/4	12-5/8
Ram Diameter (in.)	1-3/4	2-1/3
Overall Dimensions (in./ L x W x H)	40 x 26 x 28-3/4	40 x 35 x 28-3/4
Net Weight (lbs.)	115	260
Net Weight (lbs.)	19	27

FORMING HELPFUL INFO

JET WANTS TO MAKE YOUR JOB EASIER BY PROVIDING YOU WITH SOME BASIC AND HELPFUL INFORMATION ON ALL OF OUR METAL FORMING PRODUCTS AND FORMING IN GENERAL.



BENCH & FLOOR MODEL HAND BRAKES
STOCK NO. 756222



ELECTRIC SLIP ROLL
STOCK NO. 756027



FLOOR BOX AND PAN BRAKE
STOCK NO. 752127



3 IN 1 SHEAR BRAKE & ROLL
STOCK NO. 756031

JET CONVERSION CHART FOR METAL FORMING MACHINES

MILD STEEL CAPACITY (GAUGE)	24	22	20	18	16	14	12
Inch	.024	.030	.036	.048	.060	.075	.105
mm	.61	.76	.91	1.2	1.5	1.9	2.3
IRON							
Dead Soft Gauge	24	22	20	18	16	14	12
STEEL							
Low Carbon H.R. (gauge)	24	22	20	18	16	14	12
Low Carbon C.R. (gauge)	24	22	20	18	16	14	12
40% - 50% Carbon H. R. (gauge)	28	26	24	22	20	18	16
1074, 1095 C.R.							
Annealed Spring Steel (gauge)	28	26	24	22	20	18	16
Low Carbon C.R. (gauge)	26	24	22	20	18	18	16
STAINLESS STEEL							
Annealed (gauge)	28	26	24	22	20	18	16
ALUMINUM							
1100-0, 2024-0, 1100-h16	.045	.057	.068	.090	.120	.160	.200
2024-T3, 5052-H34, 6061-T6, 7075-T4	.030	.036	.048	.063	.090	.108	.125
COPPER AND ALLOYS							
Electrolytic Copper	22	20	18	16	14	12	10
Bronze Commercial	22	20	18	16	14	12	10
Brass 70-30 (gauge)	22	20	18	16	14	12	10
NICKEL ALLOYS							
Inconel 600, Monel R405 (gauge)	28	26	24	22	20	18	16
Nickel 200A, Annealed (gauge)	28	26	24	22	20	18	16



HYDRAULIC SHOP PRESS
STOCK NO. 331406

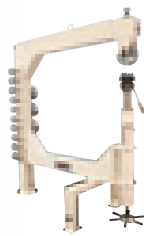

45" PROFESSIONAL ENGLISH WHEEL
STOCK NO. 756151

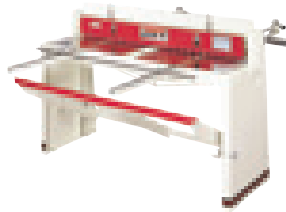

FOOT SHEAR
STOCK NO. 752652



ARBOR PRESS
STOCK NO. 333605

JET CONVERSION CHART FOR METAL FORMING MACHINES

ZINC							
As rolled (gauge)	24	22	20	18	16	14	12
PLASTICS							
ABS Compounds	.060	.090	.120	.150	.200	.225	.250
Polycarbonate	.048	.063	.075	.105	.125	.155	.188

CONVERTS SHEET METAL GAUGE NUMBERS INTO METAL THICKNESS

Gauge	26 ga.	24 ga.	22 ga.	20 ga.	18 ga.	16 ga.	14 ga.	13 ga.	12 ga.	11 ga.	10 ga.	9 ga.	8 ga.	7 ga.	6 ga.
Inch	.018"	.024"	.030"	.036"	.048"	.060"	.075"	.090"	.105"	.120"	.135"	.150"	.164"	.180"	.194"
mm	.46 mm	.61 mm	.76 mm	.91 mm	1.2 mm	1.5 mm	1.9 mm	2.3 mm	2.7 mm	3 mm	3.4 mm	3.8 mm	4 mm	4.6 mm	4.9 mm



WARRANTY AND SERVICE

JET backs every metalworking product with a FULL two year warranty. Post sale our technical support team is available to make sure your machines are operating at full capacity.



**THE INDUSTRY'S MOST
DEPENDABLE SERVICE &
SUPPORT GUARANTEE**

At JET, we understand that providing a quality products is only the beginning. We've learned over the years that in the metalworking business, if you don't have access to quick and dependable service and support, you can't conduct your business with confidence. That's why we have JET Authorized Service Centers in all 50 states, and more than 350 metalworking specific repair stations across the country. Whether you need someone to perform a warranty repair, need replacement parts, or just need to discuss routine maintenance, JET has you covered. For more information, or to find a location in your area please call 1 (800) 274-6848.

For additional information about service, support, parts or information, please visit www.jettools.com/service



METALWORKING WARRANTY



- Drill Presses
- Finishing/Grinding
- Lathes
- Metalforming
- Mill/Drills
- Mills
- Saws



- Lathe Accessories
- Machine Accessories

COVERAGE

This warranty covers any defects in workmanship or materials subject to the exceptions stated below. Cutting tools, abrasives and other consumables are excluded from warranty coverage.

This warranty covers only the initial purchaser of the product.

The general JET warranty lasts for the time period specified in the product literature of each product.

HOW TO GET SERVICE

The product or part must be returned for examination, postage prepaid, to a location designated by us. For the name of the location nearest you, please call 1-800-274-6848.

You must provide proof of initial purchase date and an explanation of the complaint must accompany the merchandise. If our inspection discloses a defect, we will repair or replace the product, or refund the purchase price, at our option.

We will return the repaired product or replacement at our expense unless it is determined by us that there is no defect, or that the defect resulted from causes not within the scope of our warranty in which case we will, at your direction, dispose of or return the product. In the event you choose to have the product returned, you will be responsible for the shipping and handling costs of the return.

WWW.JETTOOLS.COM

HOW STATE LAW APPLIES

This warranty gives you specific legal rights; you may also have other rights which vary from state to state.

LIMITATIONS ON THIS WARRANTY

WALTER MEIER LIMITS ALL IMPLIED WARRANTIES TO THE PERIOD OF THE LIMITED WARRANTY FOR EACH PRODUCT. EXCEPT AS STATED HEREIN, ANY IMPLIED WARRANTIES OR MERCHANTABILITY AND FITNESS ARE EXCLUDED. SOME STATES DO NOT ALLOW LIMITATIONS ON HOW LONG THE IMPLIED WARRANTY LASTS, SO THE ABOVE LIMITATION MAY NOT APPLY TO YOU. WALTER MEIER SHALL IN NO EVENT BE LIABLE FOR DEATH, INJURIES TO PERSONS OR PROPERTY, OR FOR INCIDENTAL, CONTINGENT, SPECIAL, OR CONSEQUENTIAL DAMAGES ARISING FROM THE USE OF OUR PRODUCTS. SOME STATES DO NOT ALLOW THE EXCLUSION OR LIMITATION OF INCIDENTAL OR CONSEQUENTIAL DAMAGES, SO THE ABOVE LIMITATION OR EXCLUSION MAY NOT APPLY TO YOU.

Walter Meier sells through distributors only. The specifications in Walter Meier catalogs are given as general information and are not binding. Members of Walter Meier reserve the right to effect at any time, without prior notice, those alterations to parts, fittings, and accessory equipment which they may deem necessary for any reason whatsoever. JET® branded products are not sold in Canada by Walter Meier.



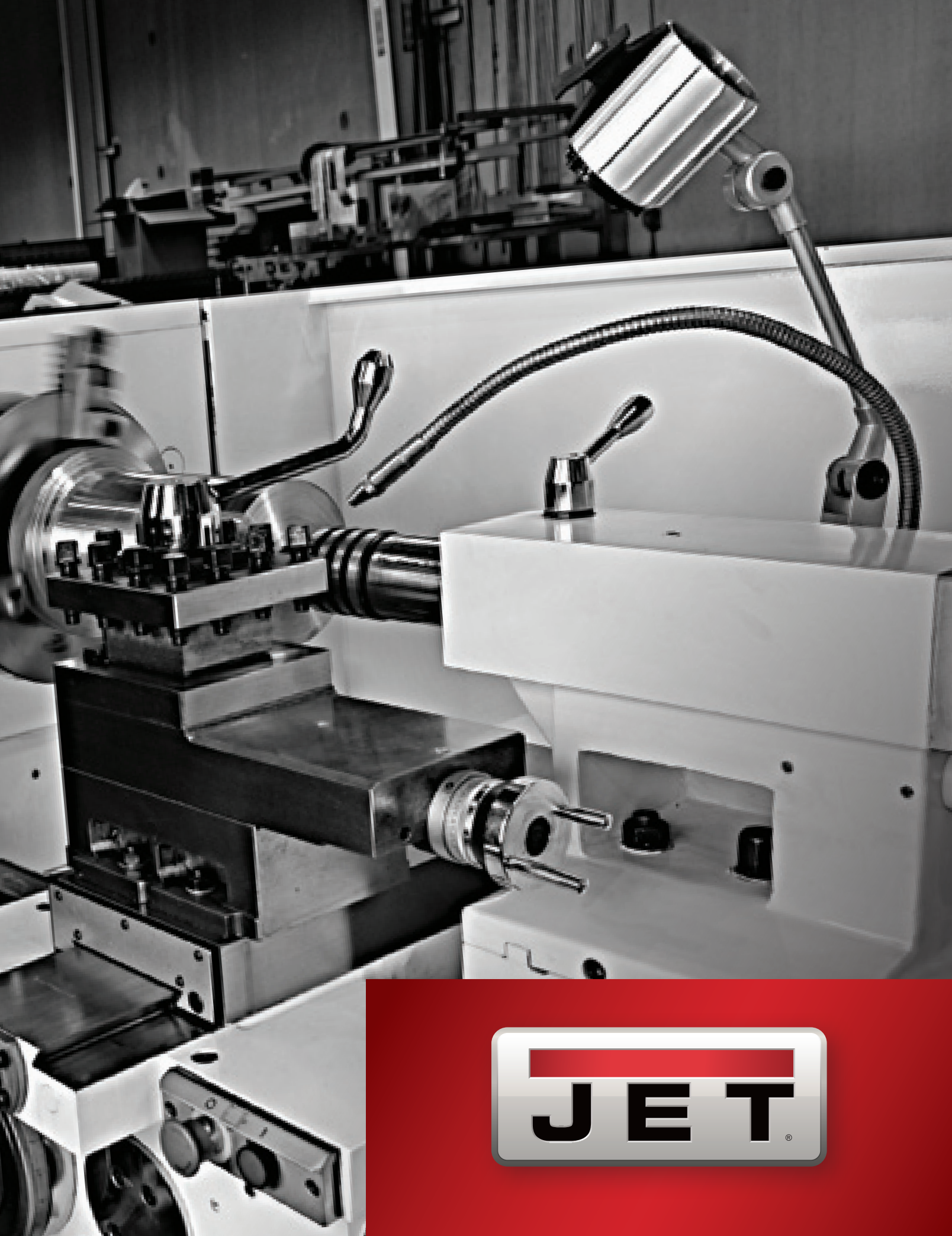

STAND BEHIND YOUR WORK



Stock No. 904408
25K 9-2012
©2012 Walter Meier (Manufacturing) Inc.
Printed in the U.S.A.

Walter Meier (Manufacturing) Inc.
Lavergne, TN 37086 U.S.A.
waltermeier.com